

SC370 43B

INSTRUCTION FOR USE

UK
CA

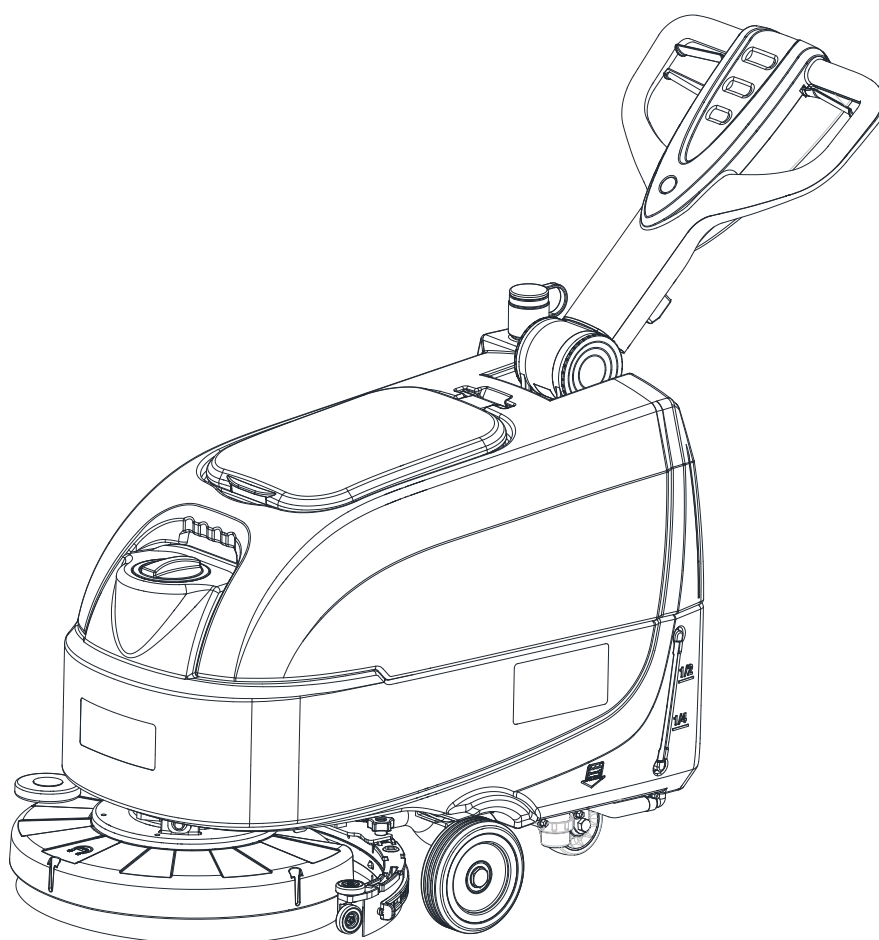
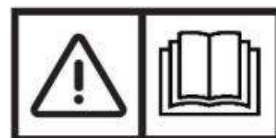

Model No.: 50000627

55942467 Rev. A JAN. 2023

Original instructions



NILFISK

EU / UE / EL / EC / EE / ES / EÚ / AB / EG

Declaration of Conformity

Prohlášení o shodě
Konformitätserklärung
Overensstemmelseserklæring
Declaración de conformidad
Vastavusdeklaratsioon
Déclaration de conformité
Vaatimustenmukaisuusvakuutus

Декларация за съответствие
Δήλωση συμμόρφωσης
Megfelelősségi nyilatkozat
Izjava o skladnosti
Dichiarazione di conformità
Atitikties deklaracija
Atbilstības deklarācija
Samsvarserklæring
Conformiteitsverklaring

Declaração de conformidade
Declaracja zgodności
Declaratie de conformitate
Декларация о соответствии
Försäkran om överensstämmelse
Vyhlasenie o zhode
Izjava o skladnosti
Uygunluk beyanı

Manufacturer / Výrobce / Hersteller / Fabrikant / Fabricante / Κατασκευαστής /
Gyártó / Proizvođač / Fabbicante / Gamintojas / Ražotājs / Produsent / Fabrikant
/ Fabricante / Producent / Producător / производитель / Tillverkaren / Výrobca /
Proizvajalec/ Üretici firma:

**Nilfisk A/S, Kornmarksvej 1
DK-2605 Broendby, DENMARK**

Product / Produkt / Producto, Toode, Produit, Tuote/ Продукт /
Προϊόν / Termék / Proizvod / Prodotto / Produktas / Produkts /
Artikel / Produtos / Prods / Izdelek / Ürün

SC370

Description / Popis / Beschreibung / Beskrivelse / Descripción /
Kirjeldus / La description / Kuvaus / Описание / Περιγραφή / Leirás /
Opis / Descrizione / Aprašymas / Apraksts / Beschrijving / Descrição /
Descriere / Beskrivning / Popis / Açıklama

**FC - Floor Scrubber/Sweeper - Battery
Working mode: 24 VDC; Charging mode:
100-240V 50-60Hz, IP24**

EN We, Nilfisk hereby declare under our sole responsibility, that the above-mentioned product(s) is/are in conformity with the following directives and standards.

BG Ние, Nilfisk с настоящото декларираме на своя лична отговорност, че посочените по-горе продуктът е в съответствие със следните директиви и стандарти.

PT Nós, a Nilfisk declaramos, sob nossa exclusiva responsabilidade, que o produto acima mencionado está em conformidade com as diretrizes e normas a seguir.

CS My, Nilfisk prohlašujeme na svou výlučnou odpovědnost, že výše uvedený výrobek je ve shodě s následujícími směnicemi a normami.

EL Εμείς, Nilfisk δηλώνουμε με αποκλειστική μας ευθύνη, ότι το προαναφερόμενο προϊόν συμμορφώνεται με τις ακόλουθες οδηγίες και πρότυπα.

PL My, Nilfisk Niniejszym oświadczamy z pełną odpowiedzialnością, że wyżej wymieniony produkt jest zgodny z następującymi dyrektywami i normami.

DE Wir, Nilfisk erklären in alleiniger Verantwortung, dass das oben genannte Produkt den folgenden Richtlinien und Normen entspricht.

HU Mi, Nilfisk kijelentjük, egyedüli felelősséggel, hogy a fent említett termék megfelel az alábbi irányelveknek és szabványoknak

RO Noi, Nilfisk Prin prezenta declarăm pe propria răspundere, că produsul mai sus menționat este în conformitate cu următoarele standarde și directive.

DA Vi, Nilfisk erklærer hermed under eget ansvar at ovennævnte produkt(er) er i overensstemmelse med følgende direktiver og standarder.

HR Mi, Nilfisk izjavljujemo pod punom odgovornošću, da gore navedeni proizvod u skladu sa sljedećim direktivama i standardima.

RU Мы, Nilfisk настоящим заявляем под нашу полную ответственность, что вышеперечисленные продукция соответствует следующими директивам и стандартам.

ES Nosotros, Nilfisk declaramos bajo nuestra única responsabilidad que el producto antes mencionado está en conformidad con las siguientes directivas y normas

IT Noi, Nilfisk dichiara sotto la propria responsabilità, che il prodotto di cui sopra è conforme alle seguenti direttive e norme.

SV Vi Nilfisk förklarar härmed under eget ansvar att ovan nämnda produkt överensstämmer med följande direktiv och normer.

ET Meie, Nilfisk Käesolevaga kinnitame ja kanname ainuisikulist vastutust, et eespool nimetatud toode on kooskõlas järgmistele direktiividele ja

LT Mes, „Nilfisk“, prisiimdami visišką atsakomybę pareiškiame, kad pirmiau minėtas produktas (-ai) atitinka šias direktyvas ir standartus

SK My, Nilfisk prehlasujeme na svoju výlučnú zodpovednosť, že vyššie uvedený výrobok je v zhode s nasledujúcimi smernicami a normami.

FR Nilfisk déclare sous notre seule responsabilité que le produit mentionné ci-dessus est conforme aux directives et normes suivantes.

LV Mēs, Nilfisk, ar pilnu atbildību apliecinām, ka iepriekšminētais produkts atbilst šādām direktīvam un standartiem

SL Mi, Nilfisk izjavljamo s polno odgovornostjo, da je zgoraj omenjeni izdelek v skladu z naslednjimi smernicami in standardi.

FI Me, Nilfisk täten vakuutamme omalla vastuulla, että edellä mainittu tuote on yhdenmukainen seuraavien direktiivien ja standardien mukaisesti

NO Vi, Nilfisk erklærer herved under eget ansvar, at det ovennevnte produktet er i samsvar med følgende direktiver og standarder

TR Nilfisk, burada yer alan tüm sorumluluklarımızı göze, yukarıda belirtilen ürünün aşağıdaki direktifler ve standartlara uygun olduğunu beyan ederiz.

NL We verklaren Nilfisk hierbij op eigen verantwoordelijkheid, dat het bovengenoemde product voldoet aan de volgende richtlijnen en normen

2006/42/EC

EN 60335-1:2012+A11:2014+A13:2017+A1:2019+A14:2019+A2:2019
EN 60335-2-72:2012

2014/30/EU

EN 55014-1:2021
EN 55014-2:2021
EN 61000-3-2:2019+A1:2021
EN 61000-3-3:2013+A1:2019

Authorized to compile
Technical File and
signatory:

Feb 9, 2023

Mads Christensen, VP R&D, Head of
Competence Center Europe • R&D



NILFISK

UK Declaration of Conformity

We,
Nilfisk Ltd
Nilfisk House, Bowerbank Way Gilwilly Industrial Estate
Penrith Cumbria
CA11 9BQ UK

Hereby declare under our sole responsibility that the

Product: FC - Floor Scrubber/Sweeper - Battery
Description: Working mode: 24 VDC; Charging mode: 100-240V 50-60Hz, IP24
Type: SC370

Is in compliance with the following standards:

EN 60335-1:2012+A11:2014+A13:2017+A1:2019+A14:2019+A2:2019
EN 60335-2-72:2012
EN 55014-1:2021
EN 55014-2:2021
EN 61000-3-2:2019+A1:2021
EN 61000-3-3:2013+A1:2019

Following the provisions of:

Supply of Machinery (Safety) Regulations 2008/1597
Electromagnetic Compatibility Regulations 2016/1091

Penrith, Feb 9, 2023



Stewart Dennett
GM/MD

TABLE OF CONTENTS

INTRODUCTION	2
GUIDE PURPOSE AND CONTENTS	2
HOW TO KEEP THIS INSTRUCTION FOR USE	2
DECLARATION OF CONFORMITY	2
ACCESSORIES AND MAINTENANCE	2
CHANGE AND IMPROVEMENT	2
SCOPE OF APPLICATION	2
MACHINE IDENTIFICATION DATA	2
TRANSPORT AND UNPACKING	3
SAFETY	3
VISIBLE SYMBOLS ON THE MACHINE	3
SYMBOLS THAT APPEAR ON THE INSTRUCTION FOR USE.....	3
GENERAL SAFETY INSTRUCTION	4
MACHINE DESCRIPTION	6
MACHINE STRUCTURE (as shown in Figure 1).....	6
CONTROL PANEL (as shown in Figure 2).....	7
DISPLAY WINDOW OF CHARGER INDICATON LIGHT (as shown in Figure 2).....	7
MACHINE SIZE	8
TECHNICAL PARAMETERS.....	9
WIRING DIAGRAM.....	10
OPERATING GUIDE	11
BATTERY CHECK/SETTING ON A NEW MACHINE	11
BATTERY INSTALLATION AND BATTERY TYPESETTING (WET OR GEL/ AGM)	12
BRUSH/PAD-HOLDER INSTALLATION AND REMOVAL.....	14
SQUEEGEE ASSEMBLE INSTALLATION AND REMOVAL	15
SOLUTION OR WASHING WATER TANK FILLING.....	16
MACHINE START AND STOP	16
MACHINE OPERATION (SCRUBBING AND DRYING).....	17
TANK EMPTYING	18
AFTER USING THE MACHINE	18
MACHINE LONG INACTIVITY	19
FIRST PERIOD OF USE.....	19
MAINTENANCE	19
SCHEDULED MAINTENANCE TABLE	19
BATTERY CHARGING	20
BRUSH/PAD CLEANING.....	21
SOLUTION FILTER CLEANING.....	22
SQUEEGEE CLEANING.....	22
SQUEEGEE BLADE CHECK AND REPLACEMENT	23
TANK AND VACUUM GRID WITH FLOAT CLEANING, AND COVER GASKET CHECK	23
ACCESSORIES/OPTIONS	24
TROUBLESHOOTING	25
SCRAPPING	25

INTRODUCTION



NOTE

The numbers in brackets refer to the components shown in Machine Description chapter.

GUIDE PURPOSE AND CONTENTS

The purpose of this instruction for use is to provide the operator with all basic information and technical characteristics, operation, machine inactivity, spare parts and safety conditions etc.
Before performing any procedure on the machine, the operators and qualified technicians must read the Instruction for Use manual. Contact our company in case of doubts concerning the interpretation of the instructions or for any further information.

HOW TO KEEP THIS INSTRUCTION FOR USE

The instruction for use must be kept near the machine, inside an adequate case, away from liquids and other substances that can cause any damage to it.

DECLARATION OF CONFORMITY

Declaration of Conformity is supplied with the machine and certifies machine conformity with the law in force.



NOTE

The copies of the original declaration of conformity are provided together with the machine documentation.

ACCESSORIES AND MAINTENANCE

All the necessary operation, maintenance and repair procedures must be made by qualified personnel, our company appointed repair center. ONLY original or approved spare parts and accessories can be used.
Contact our company customer service for any service or purchase of accessories or spare parts if necessary.

CHANGE AND IMPROVEMENT

We are committed to continuous improvement of our products, and the company reserves the right to machine changes and improvements without additional information.

SCOPE OF APPLICATION

The scrubber applies to commercial and industrial use. It is suitable for cleaning smooth and solid floor, operated by a qualified person in safe circumstances. It is not suitable for outdoor use or on carpet or rough floor cleaning.

MACHINE IDENTIFICATION DATA

The machine serial number and model name are marked on the serial label.
This information is useful. Use the following table to write down the machine identification data when requiring spare parts for the machine.

MACHINE MODEL
MACHINE SERIAL NUMBER.....

TRANSPORT AND UNPACKING

When the carrier delivers the machine, make sure the packaging and machine are both whole and undamaged. If there is any damage, inform the carrier before accepting the goods, and reserve the right to compensation for the damage.

Follow the instructions on packaging strictly when unpacking the machine.

Check the package to ensure following items are included:

1. Technical documentation including instruction for use, and Parts list.
2. Battery connection components.
3. Electronic battery charger manual (if installed) (*)

SAFETY

The following symbols indicate potentially dangerous situations. Always read this information carefully and take all necessary precautions to safeguard people and property.

VISIBLE SYMBOLS ON THE MACHINE**WARNING!**

Read all the instructions carefully before performing any operation on the machine.

**WARNING!**

Do not wash the machine with direct or pressurized water jets.

**WARNING!**

Do not use the machine on slopes with a gradient exceeding that is defined in the specifications section.

SYMBOLS THAT APPEAR ON THE INSTRUCTION FOR USE**DANGER!**

It indicates a dangerous situation with risk of death for the operator.

**WARNING!**

It indicates a potential risk of injury for people.

**CAUTION!**

It indicates a caution, or a remark related to important or useful functions.
Pay attention to the paragraphs marked by this symbol.

**NOTE**

It indicates a remark related to important or useful functions.

**CONSULTATION**

It indicates the necessity to refer to the Instruction for Use manual before performing any procedure.

GENERAL SAFETY INSTRUCTION

Specific warnings and cautions to inform about potential damages to people and machine are shown below.

**DANGER!**

- This machine must be operated by trained and authorized personnel according to guidance of the manual.
- Before performing any cleaning, maintenance, repair or replacement procedure, read all the instructions carefully, ensure to turn the machine OFF and disconnect the battery connector.
- Do not operate the machine near toxic, dangerous, flammable and/or explosive powders, liquids or vapour. This machine is not suitable for collecting dangerous powders.
- Do not wear jewelry when working near electrical components.
- Do not work under the lifted machine without supporting it with safety stands.
- When using lead (WET) batteries, they may emit inflammable gas under normal use, must keep sparks, flames, smoking materials and radiating, illuminating and burning items away from the batteries.
- When charging lead (WET) batteries, they may emit hydrogen gas which may cause explosive. Must ensure the charging environment is well ventilated and away from potential flames.

**WARNING!**

- This machine is intended for **COMMERCIAL USE**, for example in hotels, schools, hospitals, factories, shops, offices and rental businesses.
- Machines left unattended shall be secured against unintentional movement.
- In order to prevent unauthorized use of the machine, the power source shall be switched off or locked, for example by removing the key of the main switch or the ignition key.
- Check the machine carefully before each use. Ensure that all the components have been well assembled before use. Loose components may cause damage to people and properties.
- Before using the battery charger, ensure that the values of frequency and voltage indicated on the machine serial number label match those of mains.
- Never move the machine by pulling the battery charger cable. Do not allow the charging cable to become damaged by a door closing, or sharp corners. Do not run the machine over the battery charger cable. Keep the battery charger cable away from heated surfaces.
- Do not charge the batteries if the battery charger cable or the plug are damaged.
- To reduce the risk of fire, electric shock, or injury, make sure machine is off before leaving.
- Use or store the machine indoors in dry conditions, it is not allowed for outdoor use.
- The machine storage and working temperature must be between 0 °C and +40 °C, the humidity of air must be between 30% - 95%.
- Do not use the machine on slopes with a gradient exceeding the specifications shown.
- When using and handling floor cleaning detergents, follow the instructions on the labels of the detergent bottles and wear suitable gloves and other protective devices.
- Use brushes and pads supplied with the machine or defined in the manual. Using other brushes or pads could reduce safety.
- In case of machine malfunctions, ensure that these are not due to lack of maintenance. If necessary, request assistance from the authorized personnel or from an authorized Service Center.
- Take all necessary precautions to prevent hair, jewelry, and loose clothes from being caught by the machine moving parts.
- Do not use the machine in particularly dusty areas.
- Do not wash the machine with direct or pressured water jets, or with corrosive substances.
- Do not bump into shelves or scaffoldings, especially where there is a risk of falling objects.
- Do not lean liquid containers on the machine, use the relevant can holder.
- To avoid damaging the floor, do not allow the brush/pad to operate while the machine is stationary.
- In case of fire, use a dry powder fire extinguisher. Do not use liquid fire extinguishers.

- **Do not remove or modify the machine stickers.**
- **Do not tamper with the machine safety guards and follow the scheduled maintenance instructions closely.**
- **Pay attention during machine transportation when temperature is below freezing point. The water in the recovery tank and in the hoses could freeze and cause serious damage to the machine.**
- **If spare parts need be replaced, order ORIGINAL spare parts from an Authorized Dealers or Retailers.**
- **Return the machine to the Service Center if it doesn't work as usual or it is in condition such as damaged, placed outdoors, dropped into water.**
- **To ensure machine proper and safe operation, the scheduled maintenance shown in the relevant chapter of this Manual, must be performed by the authorized personnel or an authorized Service Center.**
- **The machine must be properly disposed of, due to the presence of toxic-harmful materials (batteries, etc.), which are subject to standards that require disposal in special centers (see Scrapping chapter).**
- **This machine is a cleaning tool only, not for, and is not intended for any other purpose.**
- **Always keep the openings free from dust, hairs and any other foreign material which could reduce the air flow. Do not use the machine if the openings are clogged.**
- **Use the machine only where proper lighting is provided.**
- **This machine is not intended for use by persons (including children) with reduced physical, sensory or mental capabilities, or lack of experience and knowledge.**
- **Close attention is necessary when used near children.**
- **Children should be supervised to ensure that they do not play with the machine.**
- **While using this machine, take care not to cause damage to people or objects.**
- **Cleaning and user maintenance shall not be made by children without supervision.**
- **Operators shall be adequately instructed on the use of these machines.**

MACHINE DESCRIPTION**MACHINE STRUCTURE (as shown in Figure 1)**

1. Handlebar
2. Safety switch lever
3. Handlebar adjusting lever
4. Recovery water drain hose
5. Recovery tank lid
6. Fresh water cover
7. Cover retention chain
8. Filling hose neck
9. Recovery tank
10. Solution tank
11. Brush deck bumper wheel
12. Brush/pad-holder deck
13. Brush/pad-holder
14. Solution level hose
15. Solenoid valve
16. Solution filter
17. Front wheels
18. Squeegee knobs
19. Squeegee lifting handle
20. Squeegee assembly
21. Control panel
22. Accessory parts box (*)
23. Battery charge cable holder
24. Battery charge cable
25. Security cover of charging jack
26. Charging signal lights
27. Deck lifting/lowering pedal
 - a) Pedal position when deck is lowered
 - b) Pedal position when deck is lifted
28. Caster wheel
29. Recovery water drain hose
30. Outlet cover

(*): Optional

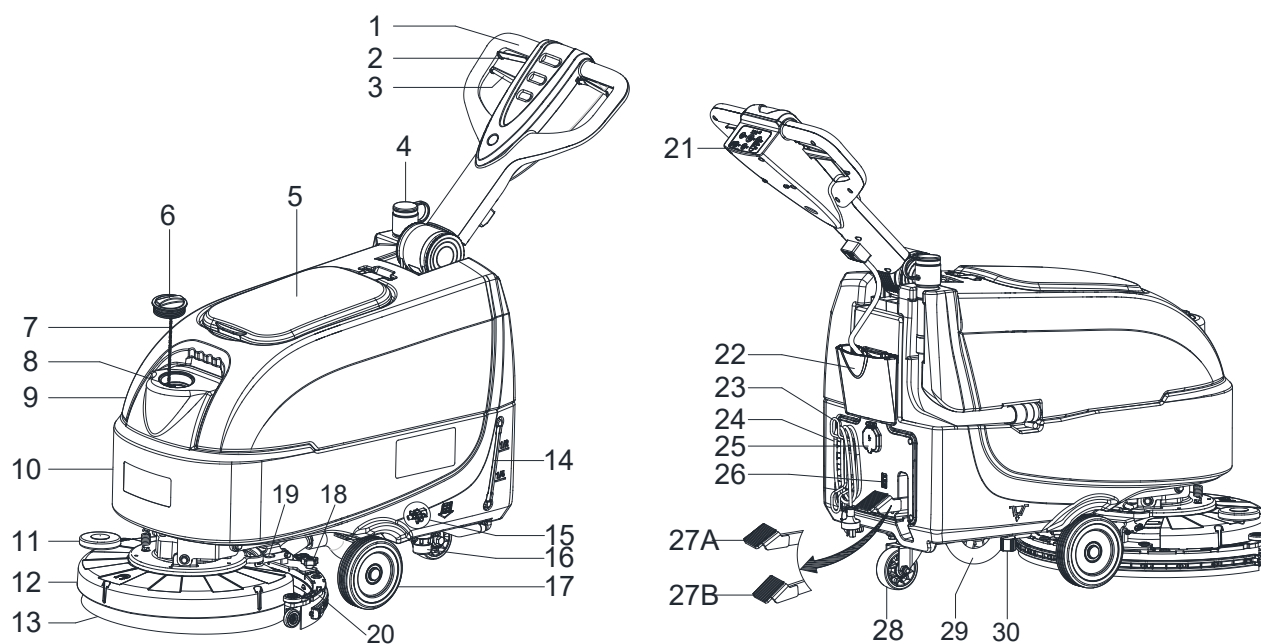
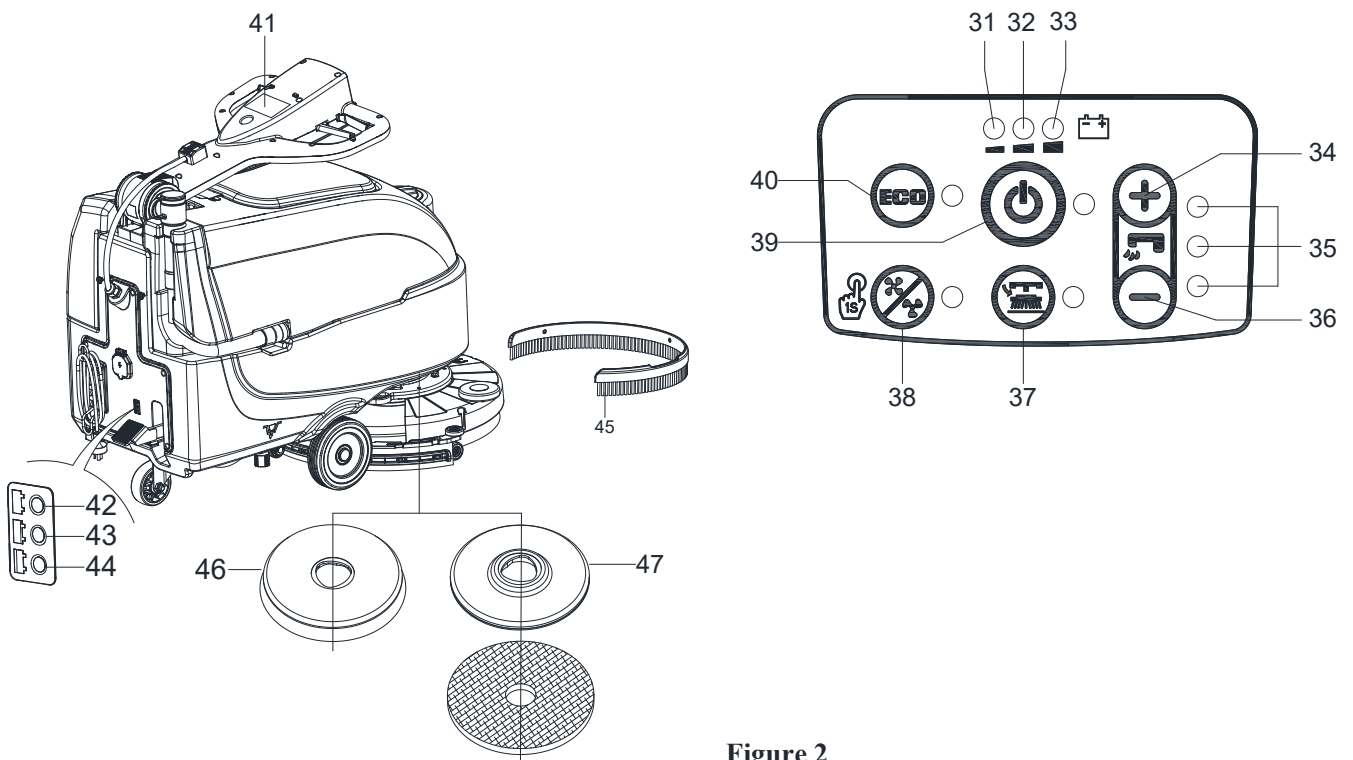

Figure 1

CONTROL PANEL (as shown in Figure 2)

- | | |
|--|--|
| 31. Discharged battery warning light (red) | 41. Serial number plate/technical data |
| 32. Semi-discharged battery warning light (yellow) | 42. Charging red LED |
| 33. Charged battery warning light (green) | 43. Charging yellow LED |
| 34. Flow increase switch | 44. Charging green LED |
| 35. Solution flow indicator | 45. Skirt (*) |
| 36. Flow decrease switch | 46. Brush |
| 37. Brush/pad-holder release switch | 47. Pad-holder (*) |
| 38. Normal vacuum motor model | |
| 39. One button starting | (*): Optional |
| 40. ECO mode | |
| 41. ECO mode | |

**Figure 2****DISPLAY WINDOW OF CHARGER INDICATON LIGHT (as shown in Figure 2)**

1. At the beginning of charging, the red LED (42) of charger is normally on. It is the first stage of charging.
2. After charging some time, the red LED (42) turns off, the yellow LED (43) turns on, this is the second stage of charging.
3. After the charging is finished, the yellow LED (43) is off, the green LED (44) turns on to indicate that the battery is fully charged.

**NOTE**

When charging, if the yellow LED (43) of charger is flashing, it may be caused by: Battery and charger does not match, battery is not connected well, or output is short-circuited.

The red LED of charger flashing may be caused by charger internal short circuit.

MACHINE SIZE

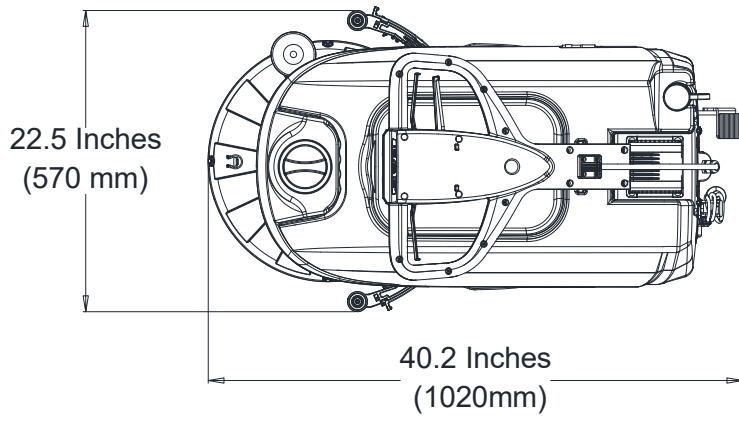
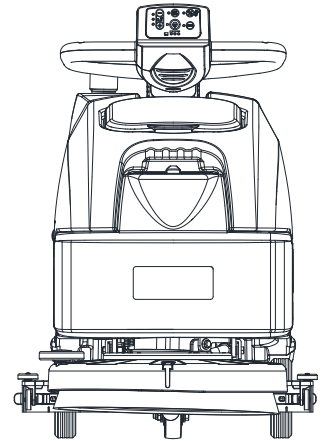
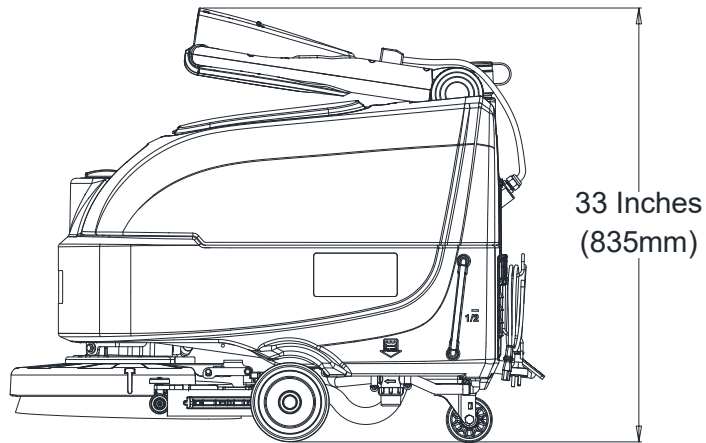

TECHNICAL PARAMETERS

Parameter Type	Units	Model
		SC370 43B
Rated Power	W / A	905W
Solution tank capacity	L / Gal	25 L / 6.6 Gal.
Recovery tank capacity	L / Gal	25 L / 6.6 Gal.
Machine Length	mm/Inches	1020 mm / 40.1 Inches
Machine width with squeegee	mm/Inches	570 mm / 22.4 Inches
Machine width without squeegee	mm/Inches	485 mm / 19.1 Inches
Machine Height (without handle)	mm/Inches	647 mm / 25.5 Inches
Machine Height (with vertical handle)	mm/Inches	1182 mm / 46.5 Inches
Working width	mm/Inches	432 mm / 17 Inches
Driving wheel diameter	mm/Inches	153 mm / 6 Inches
Rear wheel diameter	mm/Inches	89 mm / 3.5 Inches
Brush/Pad diameter	mm/Inches	432 mm / 17 Inches
Brush/Pad pressure (max)	Kg/Lbs.	19 Kg / 41.8 Lbs
Solution Flow (max) per setting	L / Gal per minute	(0.59/0.69/1.11/1.68) Liters (0.16/0.18/0.29/0.44) Gallons
Sound pressure level	dB (A)	67 ± 3 dB (A)
Sound pressure level in ECO mode or in silent mode	dB (A)	63 ± 3 dB (A)
Handle Vibration Level (max)	m/s ²	< 2.5 m/s ²
Climbing capacity (max)	% grade	2%
Min. aisle turn	cm / Inches	103cm / 40.5 Inches
Vacuum motor power	Watt / H.P.	300 W / 0.4 HP
Vacuum capacity	mm/In of H ₂ O	900 mm / 33±3 In of H ₂ O
Vacuum capacity in ECO mode or in silent mode	mm/In of H ₂ O	650 mm / 25±3 In of H ₂ O
Brush motor power	Watt / H.P.	400 Watt / 0.54 HP
Brush speed in normal mode	RPM	140 RPM
Brush speed in ECO mode	RPM	100 RPM
IP protection class	IP	IP24
Battery Compartment Size (L x W x H)	mm/Inches	(265 x 350 x 230) mm / 10.4 x 13.8 x 9.1 Inches
Voltage	DC	24 V
Batteries (*)	Ah	85Ah C20 / 67Ah C5
Battery run time (standard batteries) (*)	Hour	Up to 4 hours
On-Board Charger (*)	Volts/Amps	24V 10A
Productivity (max)	m ² /h	18,514 sq. ft./hr (1720 m ² /h)
Machine weight with empty tanks (without batteries)	Kg/Lbs.	58 Kg / 128 Lbs.
Gross Vehicle Weight (GVW)	Kg/Lbs.	134 Kg / 295 Lbs.
Shipping Weight	Kg/Lbs.	137 Kg / 302 Lbs.
Packing dimensions (L x W x H)	mm/Inches	(1130 x 730 x 1040 mm) / (44.5 x 28.7 x 41 Inches)

(*) : Optional

WIRING DIAGRAM

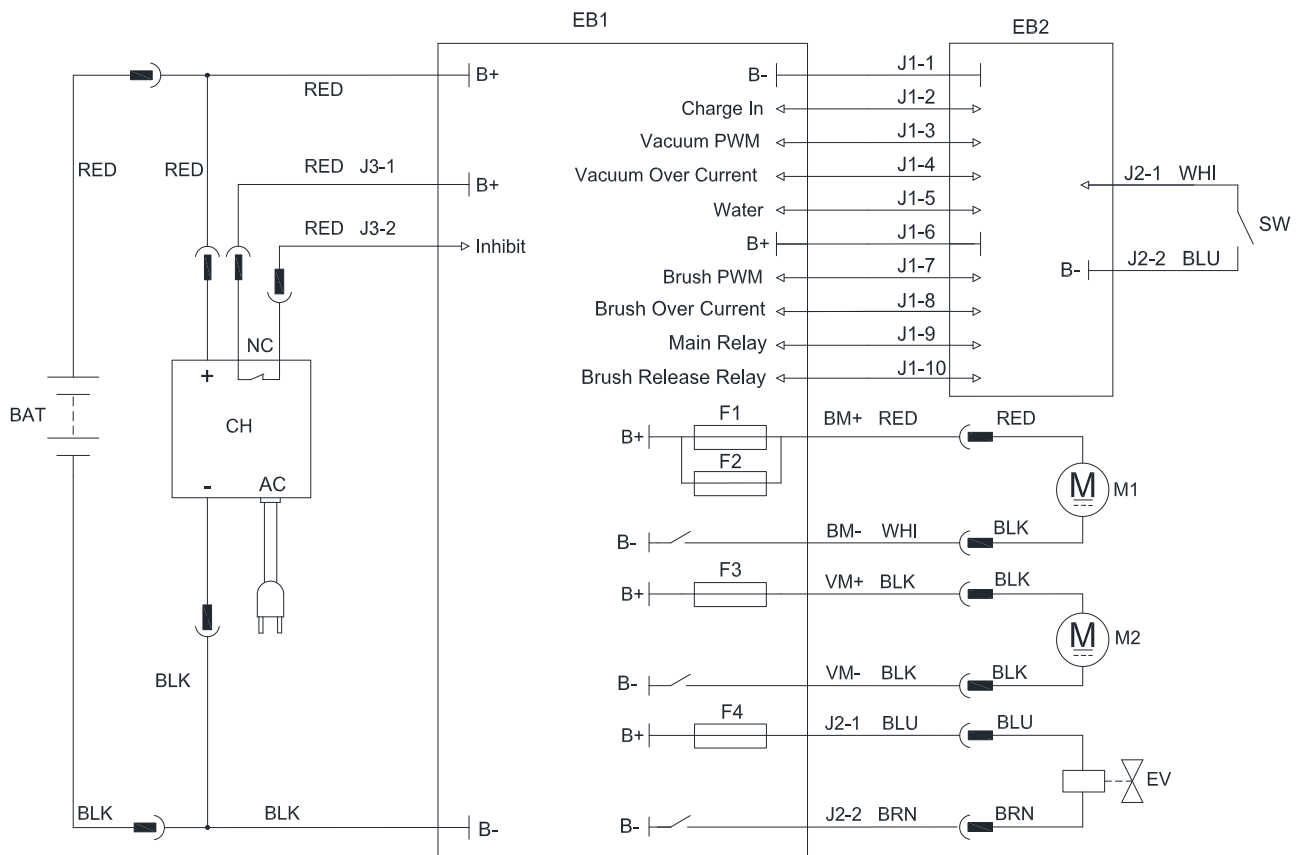

COMPONENTS		COMPONENTS	
BAT	24V Battery	SW	Handle Switch
CH	Battery Charger	F1	Brush Motor Fuse
EB1	Control Board	F2	Brush Motor Fuse
EB2	Dashboard	F3	Vacuum Motor Fuse
M1	Brush Motor	F4	Solution Valve Fuse
M2	Vacuum Motor		
EV	Solution Valve		

Comment	
1	RED-Red
2	BLK-Black
3	BRN-Brown
4	WHI-white
5	BLU-Blue

OPERATING GUIDE

**WARNING!**

On some points of the machine there are some adhesive plates indicating:

- DANGER!
- WARNING!
- CAUTION!
- CONSULTATION

While reading this Manual, the operator must pay particular attention to the symbols shown on the plates. Do not cover these plates for any reason and immediately replace them if damaged.

BATTERY CHECK/SETTING ON A NEW MACHINE

**WARNING!**

The electric components of the machine can be seriously damaged if the batteries are either improperly installed or connected. The batteries must be installed by qualified personnel only. Set the function of the electronic board and the built-in battery charger according to the type of batteries used (WET or GEL/AGM batteries). Check the batteries for damage before installation. Disconnect the battery connector and the battery charger plug. Handle the batteries with great care. Install the battery terminal protection caps supplied with the machine.

**NOTE**

The machine requires two 12 V batteries, connected according to the diagram (Figure 3).

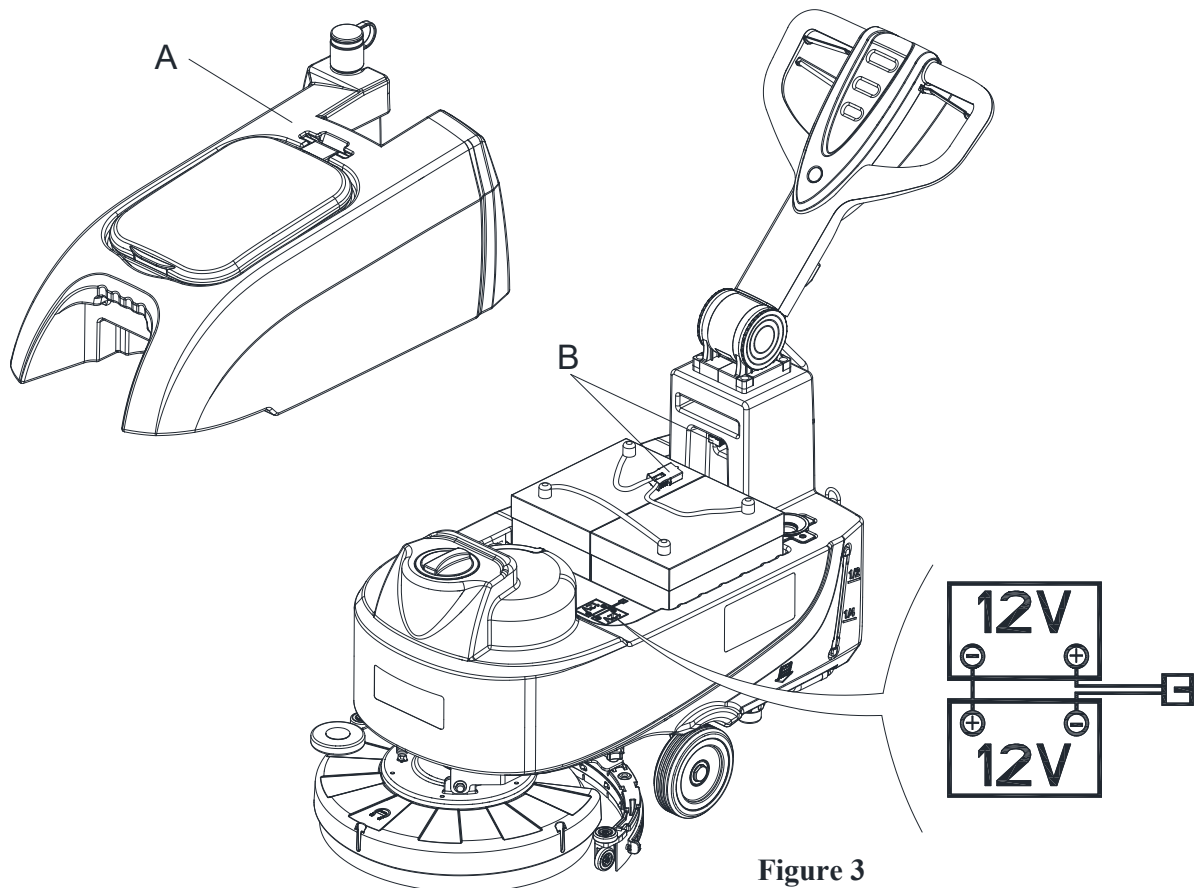

Figure 3

The machine can be supplied in one of the following modes:

A) Batteries (WET or GEL/ AGM) already installed and charged

1. Check that the batteries are connected to the machine with the connector (B, Figure 3).
2. Pressing the switch (39 Figure 2). If the green warning light (33) turns on, the batteries are fully charged. If the yellow (32) or red warning light (31) turns on, the batteries must be charged (see the procedure in Maintenance chapter).

B) Without batteries

1. Buy appropriate batteries (see the Technical Data paragraph).
2. For battery choice and installation, apply to qualified battery Retailers.
3. Set the machine and the battery charger according to the type of batteries (WET or GEL/ AGM), as shown in the next paragraph.

BATTERY INSTALLATION AND BATTERY TYPESETTING (WET OR GEL/ AGM)

According to the type of batteries (WET or GEL/AGM), set the machine and electronic board of the battery charger as follows:

Machine setting

When One-button Start S3 is turned off, press water volume + and - buttons (S5 and S6) at the same time, 0.5 seconds later, LED1, LED2 and LED3 are all lit up to enter the battery mode setting:

1. Then press water volume + or – to switch between “WET”, “GEL/AMG” and “DIS-EV”. In the the mode of “WET”, Red light is on. And “GEL/AGM”, light is green. “DIS-EV”, light is yellow.
2. Press One-button Start to finish setting and exit, turn off machine to store and update all battery setting, when it’s on, it will work as setting.



NOTE

Default battery type is GEL/AGM.

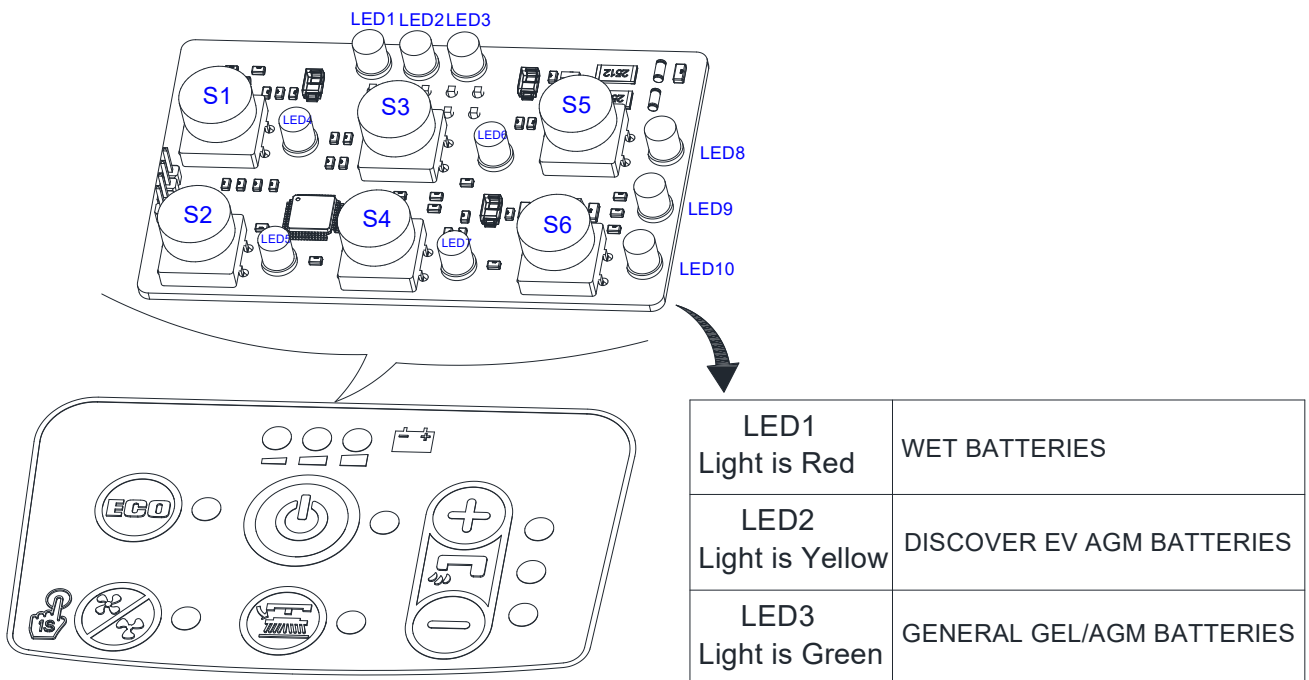

Figure 4

Battery installation

3. Open the recovery tank cover (5, Figure 1) and check that the recovery tank (9, Figure 1) is empty; otherwise empty it with the drain hose. (4, Figure 1)
4. Close the recovery tank cover (5, Figure 1).
5. Move the recovery tank kit (A, Figure 3) carefully.
6. The machine is supplied with cables suitable to install 2X12V batteries. Carefully put the batteries into the compartment, then install them correctly.
7. Route and install the battery cable as shown in (Figure3), then carefully tighten the nut on each battery terminal.
8. Place the protection cap on each terminal, then connect the battery connector (B, Figure 3).
9. Carefully put it back the recovery tank kit (A, Figure 3).

Battery charging

10. Charge the batteries. (See procedures in maintenance chapter).



CAUTION!

Cut off all the power of the machine before perform the following procedure!

Battery charger setting

11. Remove the screws (A, B, C, Figure 4.1).
12. Open the charger and find the sw1 (D, Figure 4.1).
13. Set the switches as the table of Figure 4.1.
14. Install the screws (A, B, C, Figure 4.1) after setting complete.

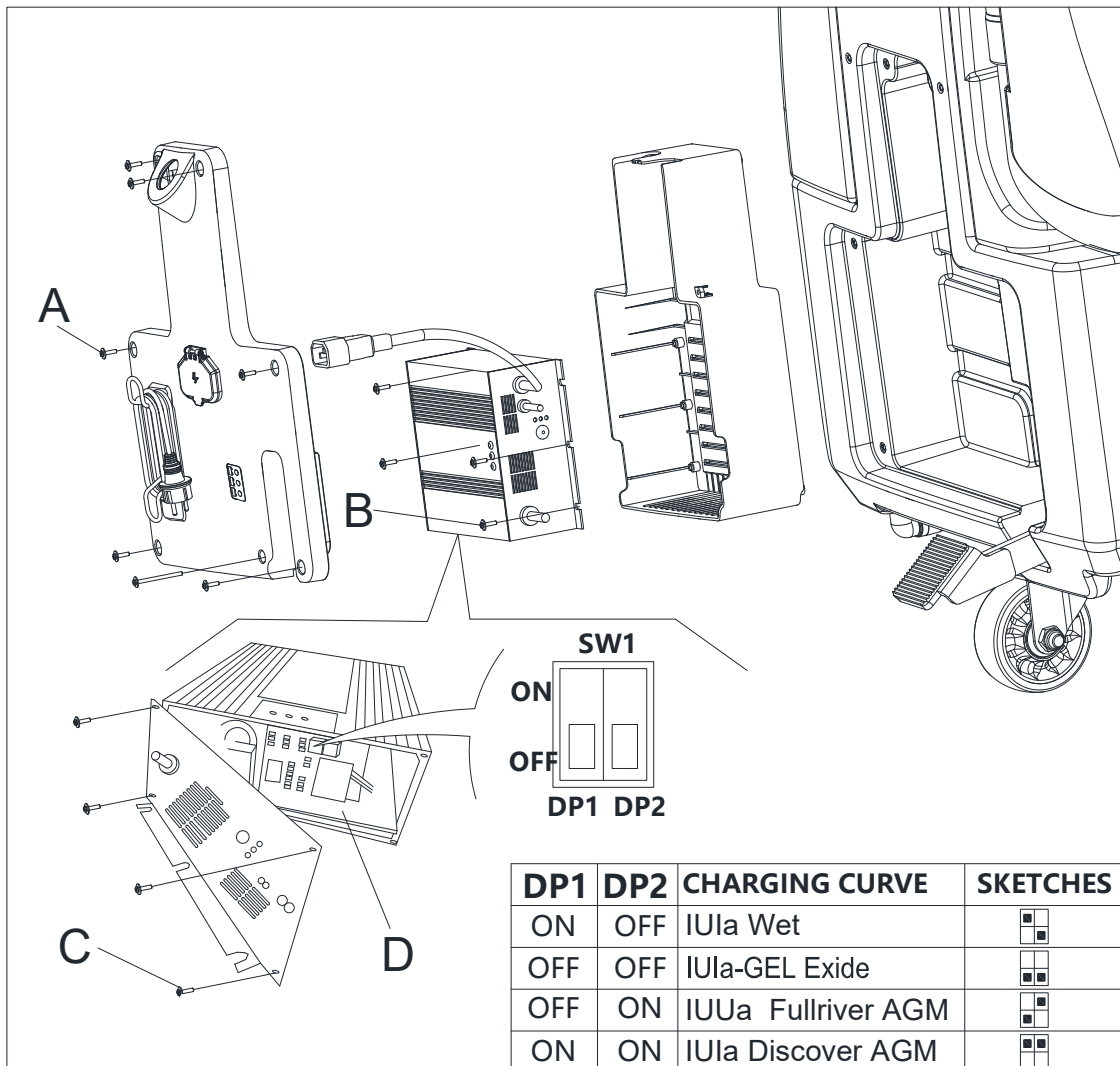

Figure 4.1

BRUSH/PAD-HOLDER INSTALLATION AND REMOVAL

**NOTE**

Install either the brush (A, Figure 5) or pad-holder (B and C, Figure 5) according to the type of floor to be cleaned.

**CAUTION!**

Before installation or removal of brush or pad-holder, make sure all the switches on machine are in off position and lifting up the squeegee and the brush/pad-holder deck from the floor. The operator must be equipped with suitable personnel protection devices such as gloves to reduce the risk of accidents.

Proceed as following:

1. Shut off the power switch (39, Figure 2).
2. Lift the deck by pressing the pedal (27, Figure 1).
3. Place the brushes (A, Figure 5) or the pad-holder (B, Figure 5) under the deck (12, Figure 1).
4. Lower the deck on the brushes/pad-holders by pressing the pedal (27, Figure 1).
5. Press the start switch (39, Figure 2).
6. Press one of the Brush/forward gear safety switch lever (2, Figure 1) to engage the brush/pad-holder, then release it. If necessary, repeat the procedure until the brushes/pad-holders are engaged.
7. If Step No.6 above proves to be difficult, use the manual method by turning the brush/pad-holder in the direction opposite to the normal turning direction, and it can be taken off. (as shown in Figure 5)

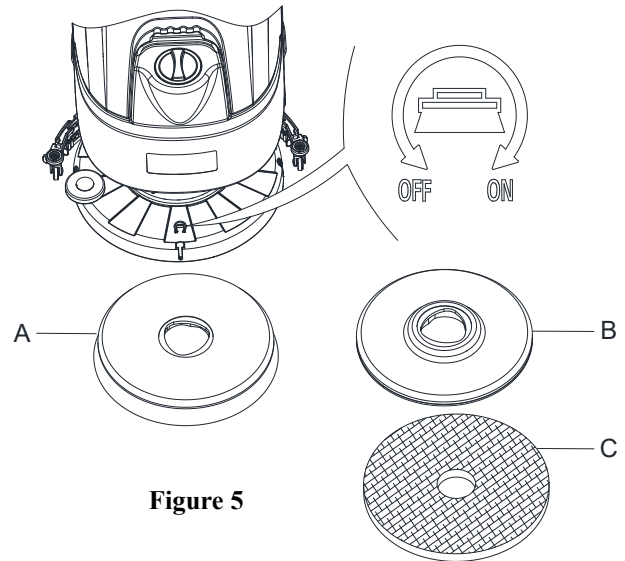

Figure 5

**WARNING!**

To engage the brush/pad-holder press the safety switch lever (2, Figure 1) which turns on the brush/pad-holder motor.

8. To remove the brush/pad-holder lift the deck by pressing the pedal (27, Figure 1), then press the switch (37, Figure 2), the brush/pad-holder will be removed.

SQUEEGEE ASSEMBLE INSTALLATION AND REMOVAL

**CAUTION!**

It is advisable to wear protective gloves when installation and removal the squeegee assemble because there may be sharp debris.

1. Push the machine to a level floor.
2. Ensure that the machine is off.
3. Lower the brush/pad-holder deck (12, Figure 1) by lifting the pedal (36), Brush on the floor.
4. Place squeegee in the place between brush deck and front wheel.
5. Fix stud A to the open B, then fix another screw D to the open C, fasten squeegee knob and connect recovery water drain hose F to the connector E (Figure 6).
6. Disconnect the squeegee in the reverse order of disassembly.

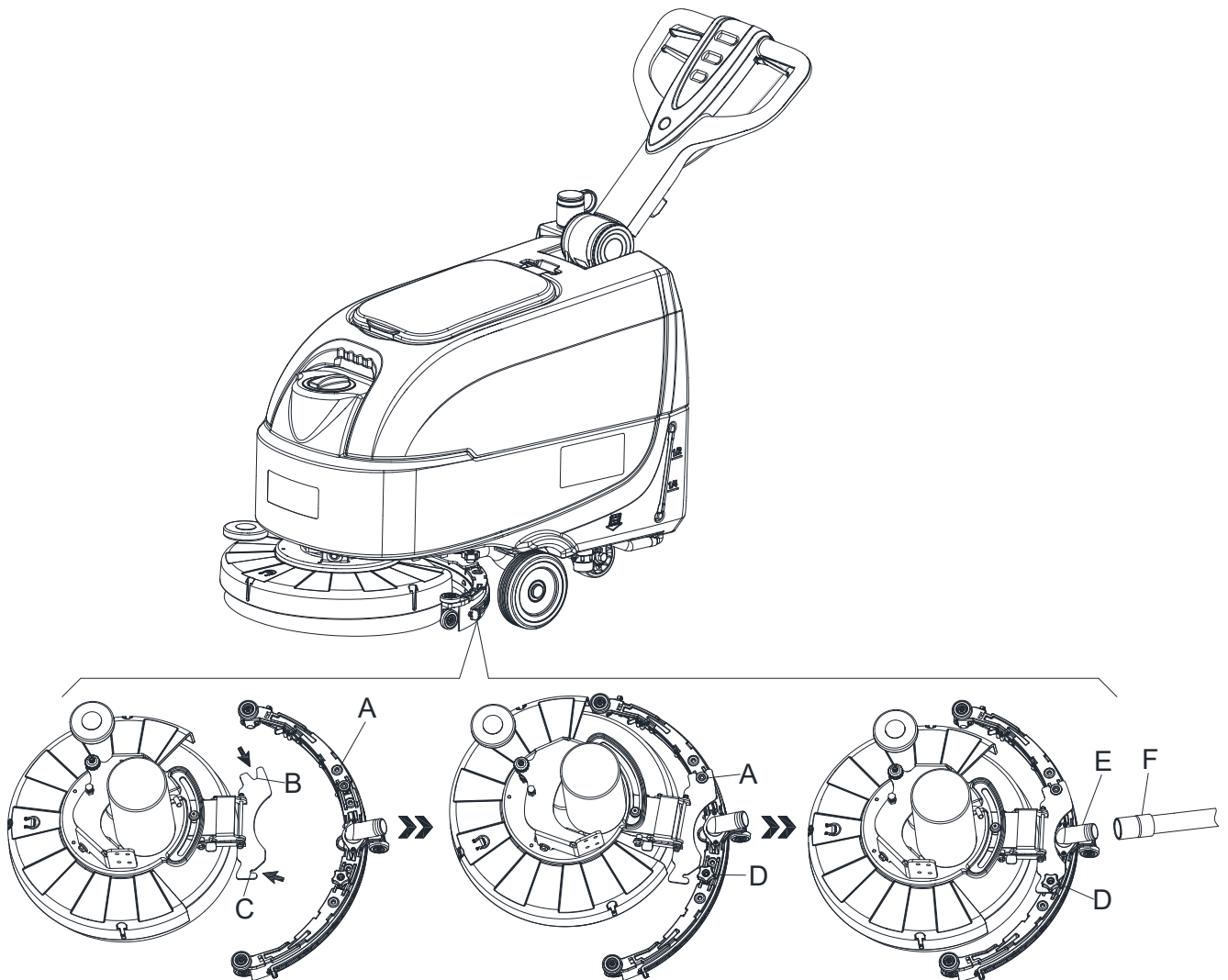

Figure 6

SOLUTION OR WASHING WATER TANK FILLING

1. Open the water inlet cover (A, Figure 7).
2. Fill with water or solution suitable for work performance.
The solution temperature must not exceed +104°F (+40°C).
3. Do not overfill the tank, refer to water level indicator (B, Figure 7) for the water volume.

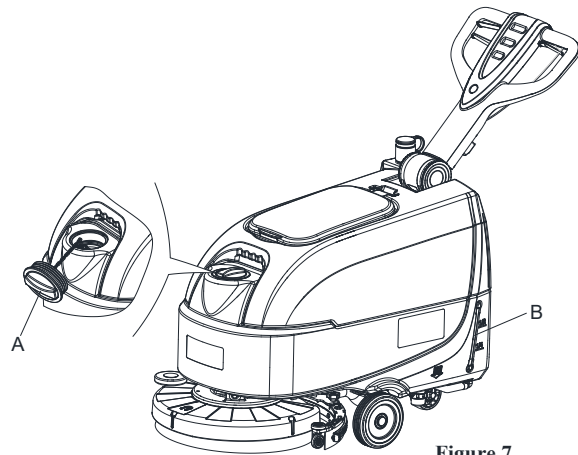

Figure 7

**WARNING!**

Use only low-foam and non-flammable detergents, intended for automatic scrubber applications.

MACHINE START AND STOP**Starting the machine**

1. Prepare the machine as shown in the previous paragraph.
2. Push the machine to the area to be cleaned, by pushing it with the hands on the handlebar (I, Figure 8).
3. Lower the brush/pad-holder deck (M, Figure 8) and the squeegee (L) by lifting the pedal (K).
4. Press the start switch (G, Figure 8). Check that the green warning light (C) turns on (charged battery). If the yellow (B) or red warning light (A) turns on, Shutoff the power switch (G, Figure 8) and charge the batteries (see the procedure in Maintenance chapter).
5. Press the washing water flow control switches (D, Figure 8) as necessary, depending on the type of cleaning to be performed.
6. Start cleaning by pushing the machine with the hands on the handlebar (I) and pressing the safety switch lever (J).

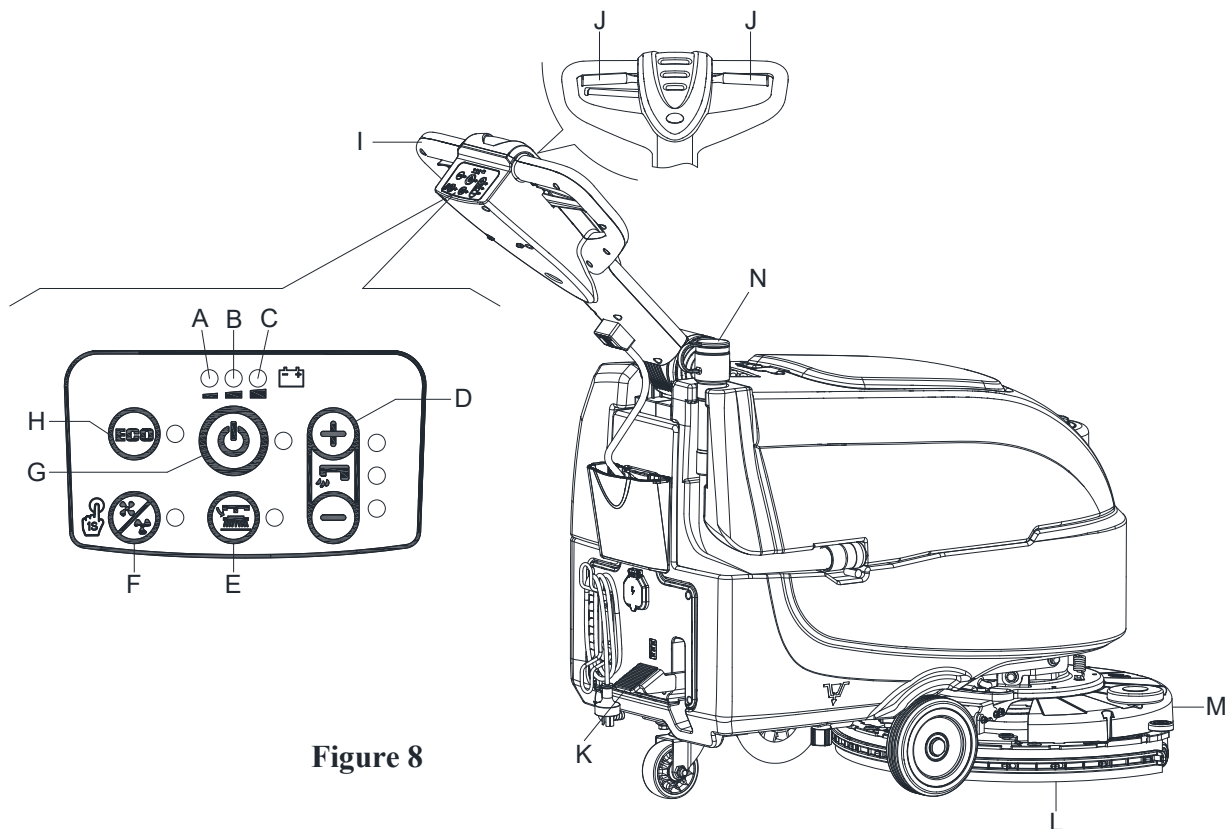

Figure 8

**NOTE**

To move the machine forward, press either the left or right safety switch lever (J, Figure 8) or both.

- If necessary, press the handlebar adjusting lever (3, Figure 1) to adjusting the handlebar height.

Stopping the machine

- Stop the machine by using the handlebar (I).
- Stop the brushes and the vacuum system by pressing the switch (G). The vacuum system stops after a few seconds.
- Lift the brush/pad-holder deck(M) and the squeegee (L) by pressing the pedal (K).
- Make sure that the machine cannot move independently.

MACHINE OPERATION (SCRUBBING AND DRYING)

- Start the machine as shown in previous paragraphs.
- While keeping both hands on the handlebar press the safety switch lever (J, Figure 8), then manoeuvre the machine and start scrubbing/drying the floor.

**NOTE**

For correct scrubbing/drying of floors at the sides of the walls, it is Suggested to go near the walls with the right side of the machine (A and B, Figure 9) as shown in the figure.

**CAUTION!**

To avoid any damage to the floor surface, turn off the brushes/pad-holders when the machine stops in one place.

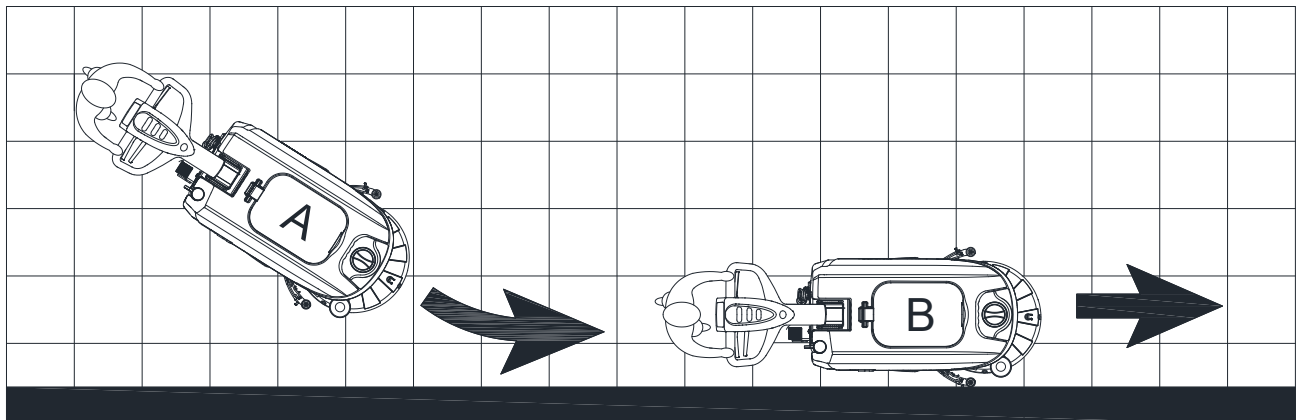

Figure 9

Battery discharge during operation

While the green warning light (C, Figure 8) stays on, the batteries allow the machine to work normally. When the green warning light (C) turns off, and the yellow warning light (B) turns on, it is advisable to charge the batteries, because the remaining charge will last for a few minutes (depending on battery characteristics and work to be performed). When the red warning light (A) turns on, batteries are fully discharged. After a few seconds, the brush/pad-holder is automatically turned off.

**CAUTION!**

Do not use the machine with discharged batteries, to avoid damaging the batteries and reducing the battery life.

TANK EMPTYING

An automatic float shut-off system (B, Figure 10) blocks the vacuum system when the recovery water tank (C) is full. The vacuum system deactivation is signaled by a sudden increase in the vacuum system motor noise frequency, also the floor has not dried.



CAUTION!

If the vacuum system turns off accidentally (for example, when the float is activated because of a sudden machine movement), to resume the operation: turn off the vacuum system by pressing the switch (G, Figure 8), then open the cover (A, Figure 10) and check that the float inside the grid (B) has gone down to the water level. Then close the cover (A) and turn on the vacuum system by pressing the switch (G, Figure 8).

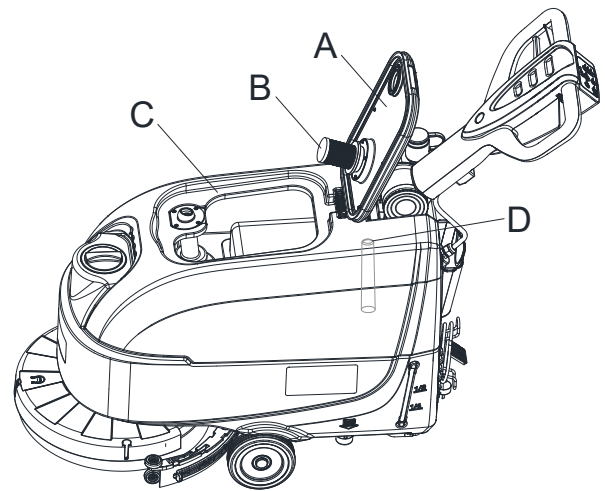

Figure 10

When the recovery water tank (C, Figure 10) is full, empty it according to the following procedure.

Recovery water tank emptying

1. Stop the machine.
2. Lift the brush/pad-holder deck (M, Figure 8) and the squeegee (L) by pressing the pedal (K).
3. Push the machine to the appointed disposal area.
4. Empty the recovery water tank with the hose (N, Figure 8). Then, rinse the recovery tank (C, Figure 10) with clean water.
5. Remove the recovery tank lid (A, Figure 10) and clean the inside of the cover and the filter floater grid (B) with clean water.
6. Check the recovery tank (D, Figure 10) whether there is foreign body jam and clean it.

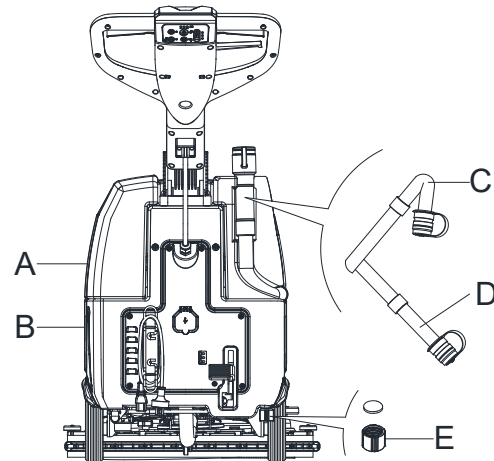

Figure 11



CAUTION!

When draining the wastewater, the vacuum tube for waste must be folded (C, Figure 11) and lowered to a lower position (D, Figure 11), and then open the lid of the vacuum tube for waste to drain the water. Do not make the outlet of the vacuum tube for waste face upward to drain the water vertically. This is to avoid wastewater spilling onto the operator.

7. Perform steps 1 to 4.

Solution/clean water tank emptying

8. Empty the solution tank with the outlet cover (E, Figure 11). After working, rinse the tank with clean water.

AFTER USING THE MACHINE

After working, before leaving the machine:

1. Remove the brushes/pad-holders.
2. Empty the tanks (A and B, Figure 11) as shown in the previous paragraph.
3. Perform the daily maintenance procedures (see the Maintenance chapter).
4. Store the machine in a clean and dry place, with the brushes/ pad-holders and the squeegee lifted or removed.

MACHINE LONG INACTIVITY

If the machine is not going to be used for more than 30 days, proceed as follows:

1. Perform the procedures shown in After Using the machine paragraph.
2. Disconnect the battery connector (B, Figure 3).

FIRST PERIOD OF USE

After the first 8 hours, check the machine fastening and connecting parts for proper tightening and check the visible parts for wear and leakage.

MAINTENANCE**WARNING!**

Maintenance procedures must be performed after the machine is turned off and the battery charger cable is disconnected. In addition, carefully read the safety chapters in the manual.

All scheduled or extraordinary maintenance procedures must be performed by qualified personnel or an authorized Service Center. This manual only describes the general and common maintenance procedures.

SCHEDULED MAINTENANCE TABLE**CAUTION!**

The procedure marked with (1) must be performed when the machine is used after 9 hours for the first time. The procedure marked with (2) must be done by Service Center that is qualified by our company.

Procedure	Daily, after each use	Weekly	semiannually	Yearly
Battery charging				
Squeegee cleaning				
Brush/Pad-holder cleaning				
Tank cleaning				
Tank sealing strip inspection				
Float ball filter cleaning				
Squeegee blade check and replacement				
Cleaning water filter cleaning				
Solution filter cleaning				
WET battery fluid level check				
Screw and nut tightness inspection			(1)	
Brush/Pad-holder carbon brush check or replacement				(2)
Suction motor carbon brush check or replacement				(2)

BATTERY CHARGING**Preliminary procedures**

1. Open the cover (C, Figure 12) and check that the recovery water tank (B) is empty, otherwise empty it with the drain hose (A).
2. Carefully move the recovery tank kit (B, Figure 12).
3. Connect the battery connector (D, Figure 12).
4. Carefully put it back the recovery tank kit (B, Figure 12).
5. Pushing the machine on a level floor.
6. Press the start switch (G, Figure 12).
7. For WET batteries only:
 - Check the level of electrolyte inside the batteries (F); if necessary, top up through the caps.
 - Leave all the battery caps open for next charging.
 - If necessary, clean the upper surface of the batteries (F).
8. Charge the batteries according to the following procedure.

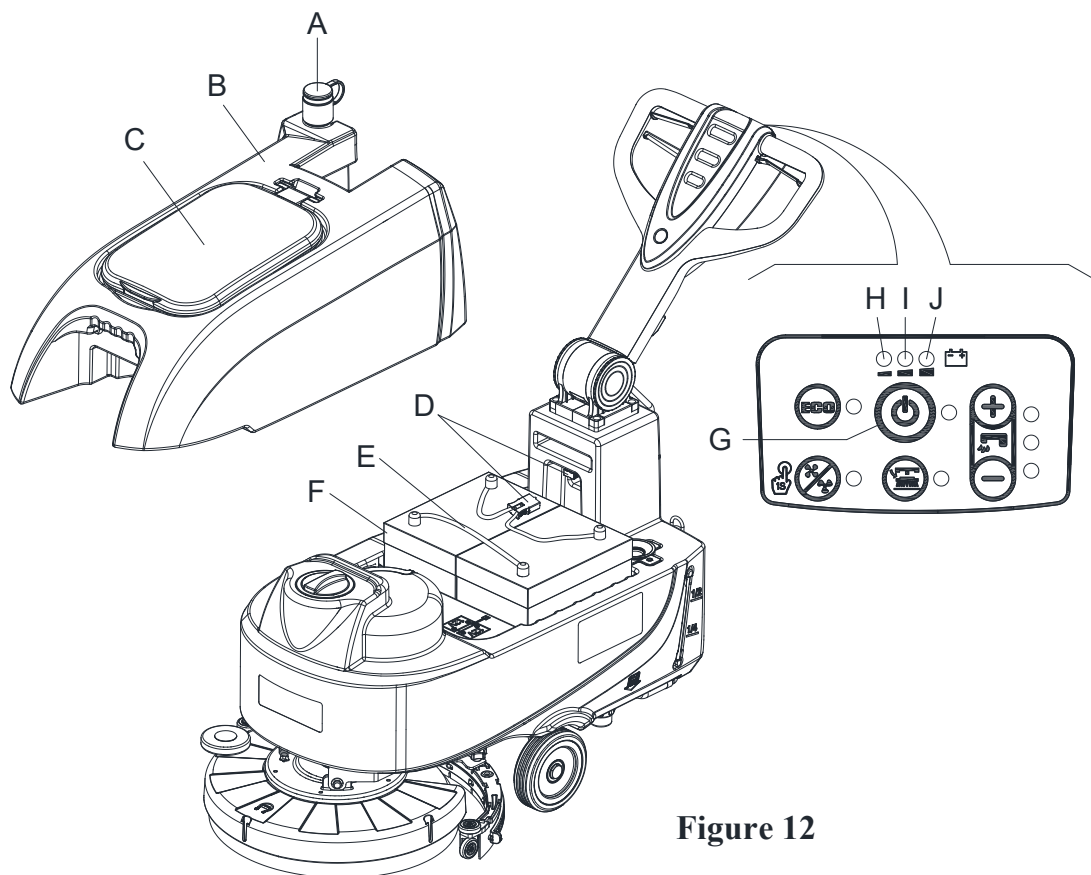

Figure 12

**NOTE**

Charge the batteries when the yellow (I, Figure 12) or red warning light (H) turns on, or when finishing cleaning.

**CAUTION!**

Keeping the batteries charged makes their life last longer.

**CAUTION!**

When the batteries are discharged, charge them as soon as possible, as that condition makes their life shorter. Check for battery charge at least once a week.

**WARNING!**

WET battery charging produces highly explosive hydrogen gas. Charge the batteries in well-ventilated areas and away from naked flames. Do not smoke while charging the batteries. Keep the tank open while charging the batteries.

**WARNING!**

Pay careful attention when charging the batteries as there may be battery fluid leakages. The battery fluid is corrosive. If it comes in contact with skin or eyes, rinse thoroughly with water and consult a physician.

Battery charging with battery charger installed on the machine

1. Connect the battery charger cable (C, Figure13) to the electrical mains (A) the electrical mains voltage and frequency must be compatible with the battery charger values shown on the machine serial number plate (41, Figure 2). When the battery charger is connected to the electrical mains, all machine functions are automatically cut off. If the red warning light (E) on the battery charger control panel stays on, the battery charger is charging the batteries.
2. When the green warning light (D) turns on, the battery charging is completed.
3. When the battery charging is completed, disconnect the battery charger cable (C) from the electrical mains (A) and wind it round its housing (B).

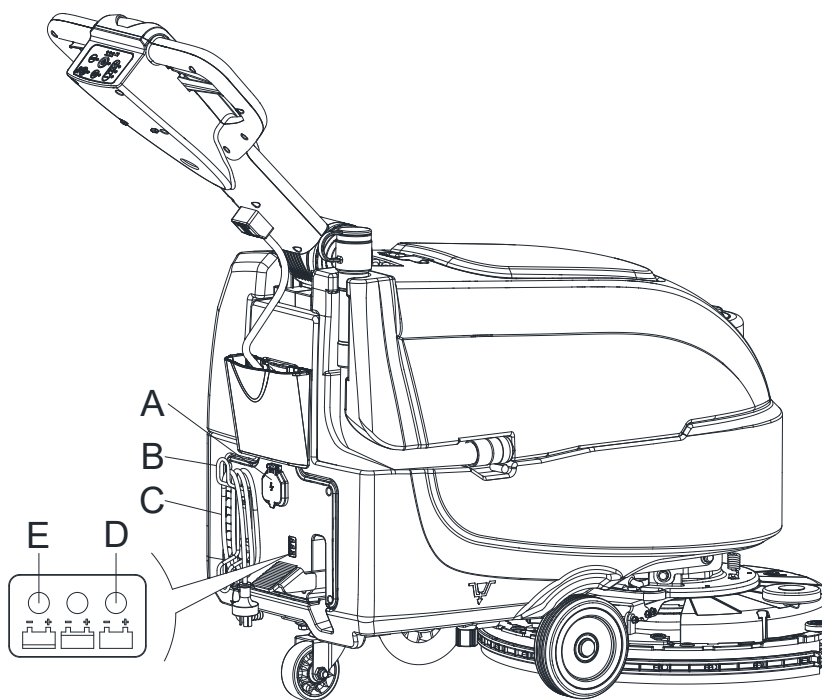

Figure 13

**NOTE**

For further information about the operation of the battery charger, see the relevant Manual.

BRUSH/PAD CLEANING**CAUTION!**

It is advisable to use protective gloves when cleaning the brush/pad because there may be sharp debris.

1. Remove the brush/pad from the machine, as shown in the Use chapter.
2. Clean and wash the brush/pad with water and detergent.
3. Check that the brushes/pads are in working condition and not excessively worn; if necessary replace them.

SOLUTION FILTER CLEANING

1. Pushing the machine on a level floor.
2. Ensure that the machine is off.
3. Emptying the solution tank (Advice).
4. Remove the cover (D, Figure 14), then remove the filter strainer (E).
Clean and install them on the support (F).

**NOTE**

The filter strainer (E) must be correctly positioned on the housing (H) of the support (F).

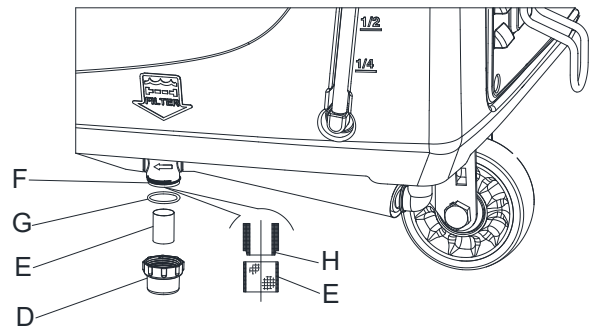
**Figure 14****SQUEEGEE CLEANING****NOTE**

The squeegee must be clean and its blades must be in good conditions in order to get a good drying.

**CAUTION!**

It is advisable to wear protective gloves when cleaning the squeegee because there may be sharp debris.

1. Push the machine to a level floor.
2. Ensure that the machine is off.
3. Lower the brush/pad-holder deck (M, Figure 8) and the squeegee (L) by lifting the pedal (K).
4. Disconnect the vacuum hose (B, Figure 15) from the squeegee (C).
5. Loosen the knobs (D) and remove the squeegee (E).
6. Clean the steel or the plastic squeegee (E, Figure 15). Clean the compartments (I) and the hole (H) especially. Check the front blade (F) and the rear blade (G) for integrity, cuts and tears; if necessary replace them (see the procedure in the following paragraph).
7. Assemble the squeegee in the reverse order of disassembly.

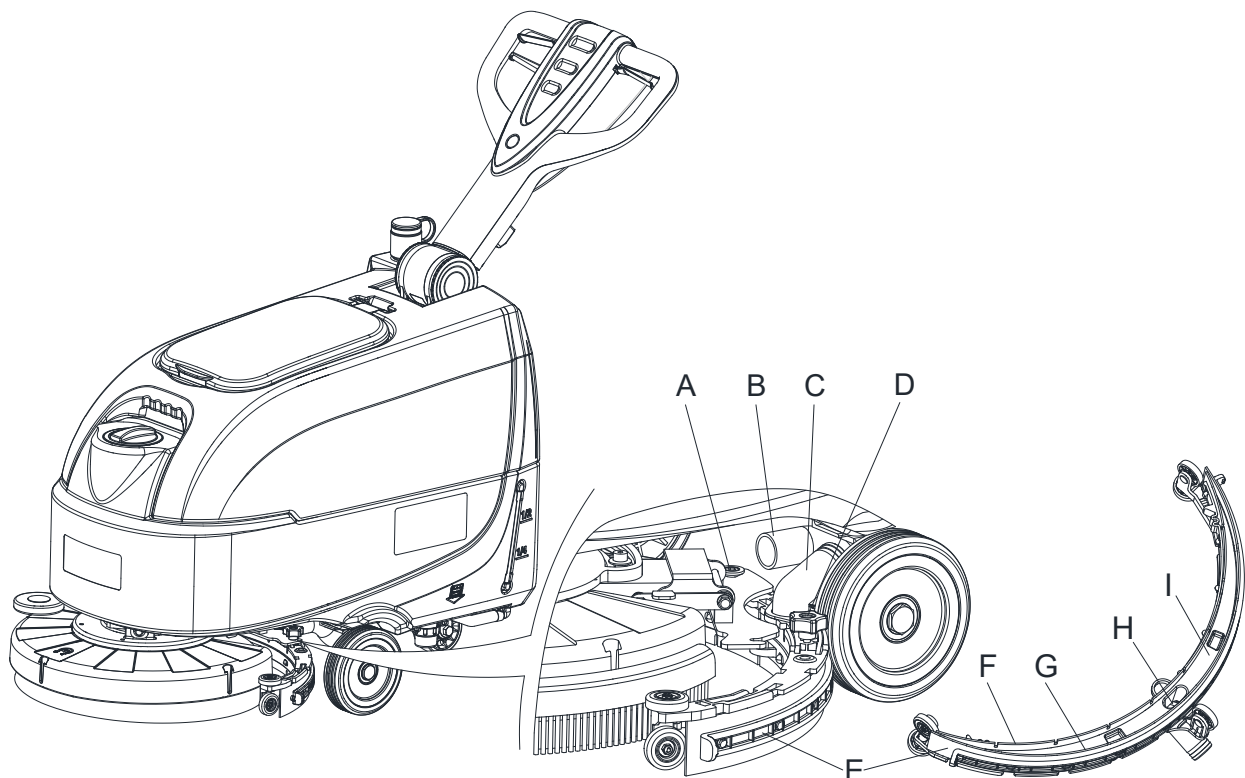
**Figure 15**

SQUEEGEE BLADE CHECK AND REPLACEMENT

1. Clean the squeegee as shown in the previous paragraph.
2. Check the condition of the front (A, Figure 16) and rear (C) blades, ensuring there are no cuts and tears; if necessary, replace them as shown below. Check that the front corner (F) of the rear blade is not worn; otherwise, turn the blade to replace the worn corner with one of the three remaining intact corners. If the other corners are worn too, replace the blade according to the following procedure:
 - Using the tab (G), release and remove the elastic strap (D) from the fasteners (H), then turn or replace the rear blade (C).
 - Install the rear blade in the reverse order of removal. Fasten the elastic strap (D) to the fasteners (H) starting from one side. To make the fastening procedure easier, secure the fasteners one at a time, by locking the strap before the fastener with one hand and pulling it with the other hand.
 - Remove the fastening strap (B) by disengaging it from the fasteners (J).
 - Replace (or overturn) the front blade (A), then reinstall the fastening strap (B).
3. Install the squeegee (E, Figure 15) and screw down the knobs (D, Figure 15).
4. Connect the vacuum hose (B, Figure 15) to the squeegee (C, Figure 15)

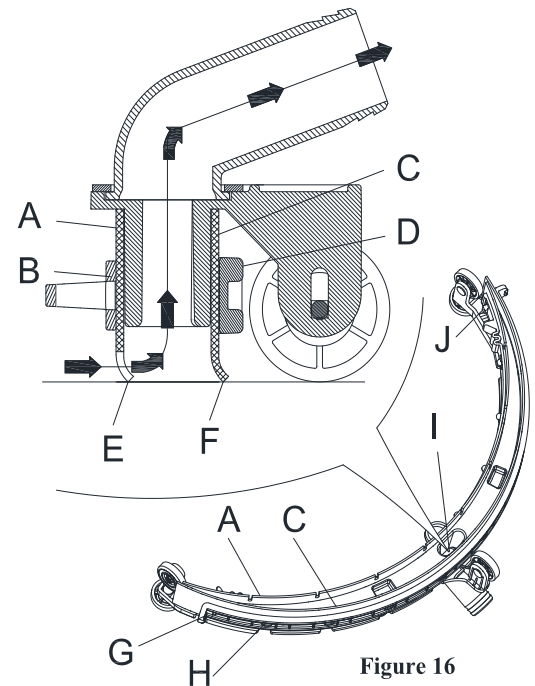

Figure 16

TANK AND VACUUM GRID WITH FLOAT CLEANING, AND COVER GASKET CHECK

1. Push the machine to a level floor.
2. Ensure that the machine is off.
3. Turn the recovery tank lid (A, Figure 17) 90 degrees position where it can be taken off from the recovery tank, and then take out the float ball filter (B) from the recovery tank lid.
4. Clean the recovery tank lid (A), recovery tank (C), clean solution tank (D) and the float ball filter (B). Empty the recovery tank with the drain hose (D, Figure 11).
5. Install the float ball filter (B) and the recovery tank lid (A).
6. Inspect the integrity of the tank sealing strip.

**NOTE**

The tank sealing strip (E) produces the vacuum inside the tank when the vacuum motor works. The tank must be sealed so it can effectively absorb the water from the ground to recovery tank.

7. Check whether the contact surface of sealing strip (E) has integrity and sealing is sufficient. If necessary, take the sealing strip of the tank out of the groove (F) and replace it. Assemble the new sealing strip as shown in (Figure 17), the joint should be back in the middle area.
8. Close the recovery tank lid (A).

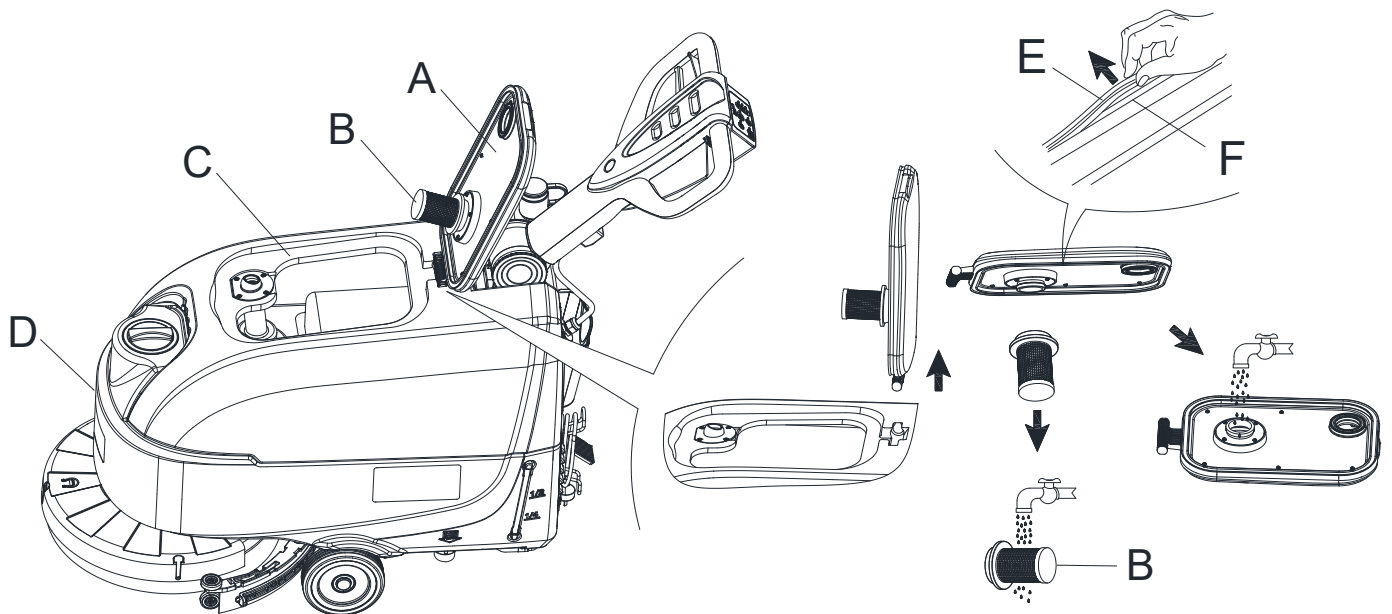

Figure 17

ACCESSORIES/OPTIONS

In addition to the standard components, the machine can be equipped with the following accessories/options, according to the machine specific use:

For further information concerning the above-mentioned optional accessories, contact an authorized Retailer.

ACCESSORIES/OPTIONS

See "Parts List" section

1. GEL/AGM batteries
2. Pads of different materials
3. Brush of different materials
4. On-board charger
5. Squeegee blades of different materials

TROUBLESHOOTING

Trouble	Probable causes	Remedy
The motors do not work; no warning light turns on.	The battery connector is disconnected.	Connect the battery connector.
	The batteries are completely discharged.	Charge the batteries.
Press one-start button S3, Indicator light flashes and power indicator light is on.	Brush motor overload, Vacuum motor overload.	Use less aggressive brushes, check if vacuum motor or brush motor is in working.
	Foreign materials (tangled threads, etc.) which may prevent the brush from rotating.	Clean the brush hub.
The brushes do not work, the red warning light is on.	The batteries are discharged.	Charge the batteries.
The recovery water vacuuming is insufficient.	The recovery water tank is full.	Empty the tank.
	The hose is disconnected from the squeegee.	Connect.
	The vacuum grid is clogged, or the float is stuck closed.	Clean the grid or check the float.
	The squeegee is dirty or the squeegee blades are worn or damaged.	Clean and check the squeegee.
	The tank cover is not properly closed, or the gasket is damaged, or the Bend tube is clogged.	Close the cover correctly or replace the gasket or clean the Bend tube.
	The recovery water tank is dirty.	Clean.
The solution flow to the brushes is insufficient.	The solution/clean water filter is dirty.	Clean the filter.
The squeegee leaves marks on the floor.	There are debris under the squeegee blades.	Remove the debris.
	The squeegee blades are worn, chipped or torn.	Replace the blades.
	The squeegee has not been adjusted with the knob.	Adjust.
Power indicator lights are all on.	High battery Voltage.	Choose suitable battery voltage.

**NOTE**

Machine with battery charger installed, cannot operate if the charger is not on board. In case of battery charger malfunction, contact an authorized Service Center.

For further information refer to the Service Manual, available at any Service Center.

SCRAPPING

Scrap the machine by the qualified waste treatment institution.

Before the machine is scrapped, please take away and segregate below subassembly that relevant laws and regulations request must be disposed in appropriate way.

- Battery
- Brush/Pad-holder
- Plastic hose and plastic parts
- Electrical and electronic components (*)

(*) Please contact our company service center destroying any electrical and electronic components.

Machine material composition and recyclability

Type	Recyclable percentage	SC370 43B weight percentage%
Aluminium	100%	2%
Electric motors-various	29%	23%
Ferrous materials	100%	32%
Wiring harness	80%	1%
Liquids	100%	0%
Plastic-non-recyclable material	0%	1%
Plastic-recyclable material	100%	38%
Rubber	20%	3%

Nilfisk A/S
Kornmarksvej 1 DK-2605 Broendby Denmark
Tel:+45 43 23 81 00 Fax:+45 43 43 77 00
www.nilfisk.com

