

Agile performance
for every kind of clean



NILFISK

Agenda

1

Introduction

2

Key Segments

3

Key Benefits

4

New Packages

5

Appendix



Entirely Redefined Platform



- Approximately 80%+ parts commonality w/SC5000
- With SC4000 launch BR755/855 - Advenger has been pruned (March 2023)
- With SC5000 launch Adgressor has been pruned previously

Key Customer Segments

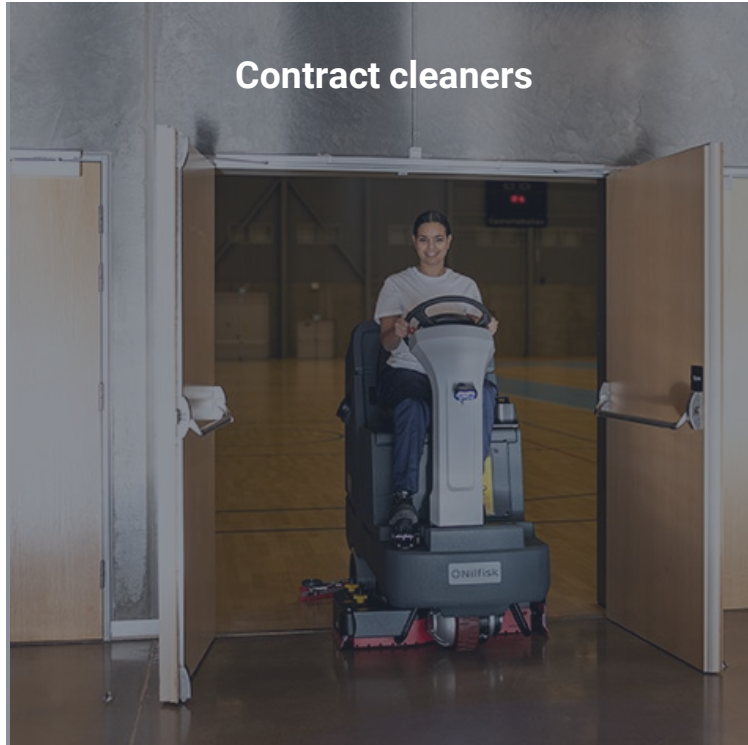

Target Segments:

Institution – Education/Health ●
Retail and Contract Cleaners ●
Warehouse & Logistics ●

Manufacturing ○
Food & Beverage ○

Agile performance for every kind of clean

Unmatched Reliability

Proven cylindrical-deck design increases lifespan by up to 4x

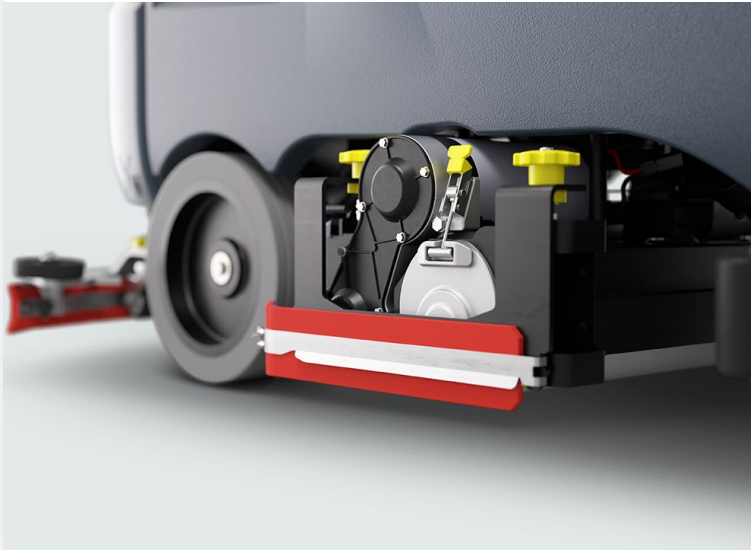

Easier than Ever

Make seamless, on-the-go adjustments while staying in control



Quick and Nimble

Fits standard doorways maximising productivity in tight spaces with a best-in-class turning radius (166cm)



Unmatched Reliability

- **Up to 4x the lifespan** exhibited by competitor products – proven design already being used on SC5000/6000
- Improved reliability and lifespan with new self-contained, sealed cylindrical brush-drive mechanism – protecting belts and pulleys from exposure to harsh cleaning environments
- Reduced maintenance costs and downtime with dual-bearing idler with dedicated seal – providing improved support and protection from water and chemical exposure

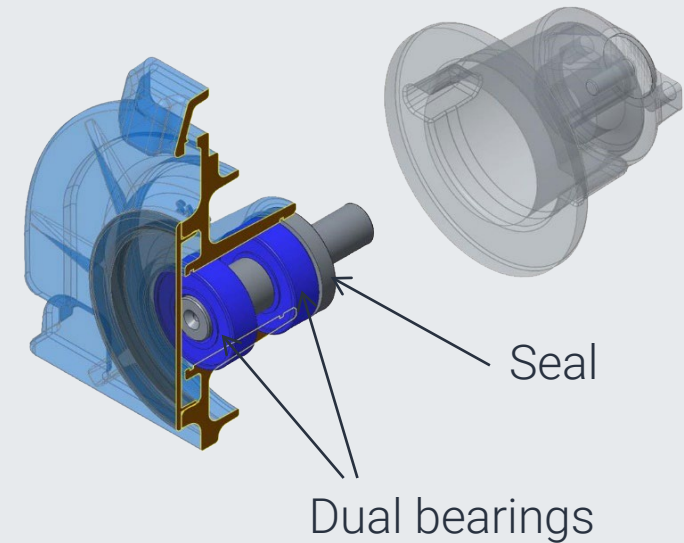
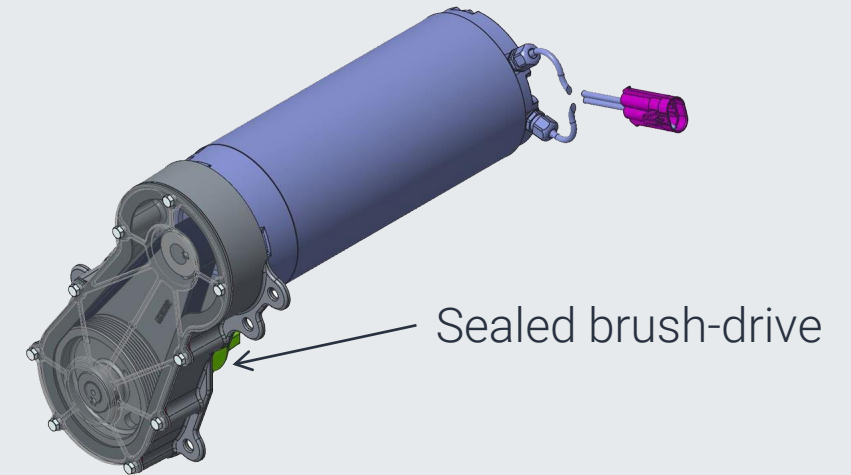

Easier than Ever

- Seamless, **on-the-go adjustments** with all command functions integrated into steering wheel
- Easy setup and scrub adjustment with **One-Touch™**
- Ensure cleaning is performed consistently no matter who is operating the machine with **SmartKey™**
- Reduce service and downtime costs with fully-embedded machine diagnostics and impact detection



Quick and Nimble

- Superior maneuverability and **best-in-class turning radius (166cm)*** – perfect for narrow aisles becoming increasingly common in warehousing
- Get the job done faster – adjustable speed up to 4.35mph on standard machine and 5.0mph with HP option(both in transportation or working mode)
- Clean safely and more efficiently – **Clear-View™** provides improved visibility of surroundings



Advenger

**65.5in (166cm) on 28C/28D/28Rev and 68.5in (174cm) on 32C/34D machines*

SMARTFLOW™

- Increase productivity by extending time between dump-and-refill by up to 50%
- Reduce costs and environmental impact by using up to 50% less water and detergent
- Solution flow rate automatically adjusts to dispense proportionate to the area cleaned, compensating for changes in speed (turns, edge-cleaning, obstacles)



ECOFLEX™

Are some parts of your facility dirtier than others?

- Clean optimally and avoid waste by adjusting cleaning power based on when it is needed
- 4 cleaning modes (at touch of a button):
 - Water Only for low soil areas
 - Burst of Power
 - Ultra-Low Detergent for light soil
 - Standard Detergent for heavy soil
- Burst of Power temporarily increases water flow, brush pressure, and detergent strength for 60 seconds (up to 300 sec)



SMARTKEY™



- Ensure cleaning is performed consistently no matter who is operating the machine
- Prevent unauthorised usage
- Provides three different access levels:
 - User (blue) – Basic functional access as defined by supervisor; operator accountability ensured via unique ID
 - Superuser (yellow) – Parameter-setting and user level-limitation of settings
 - Technician – Full access to configuration and diagnostics



Available accessories

Accessory	Description
56116355	VACUUM WAND KIT
56116358	SOLUTION AUTO FILL KIT
56116614	BATTERY WATERING KIT-36V
56116619	MOP HOLDER KIT
56116856	USB KIT
56117658	RH BROOM KIT (32C only)
56117688	SEAT BELT KIT
56117811	SCRUB-N-VAC TOOL KIT
56117858	BLUE LIGHT KIT
56117869	FOOT GUARD KIT
56117893	SOLUTION DRAIN HOSE EXTENSION

Accessory	Description
56117906	WASH HOSE KIT
56120192	DRAIN HOSE ASSEMBLY
56120260	HEADLIGHT KIT-SC4000
56120261	VACUUM KIT-HIGH POWER
56120300	SQUEEGEE GUARD KIT
56120309	BEACON KIT
56120349	ECOFLEX KIT
56120353	CLICK-ON 28D KIT
56120354	CLICK-ON 34D KIT
56120485	DELUXE SIDE SKIRT KIT
56383189	ARM REST KIT-R/H ONLY

6

Appendix

Impressive features

Squeegee

Squeegee is extremely easy to remove, or install, via ergonomic handles and guides for the squeegee support; requires no hose connection/disconnection

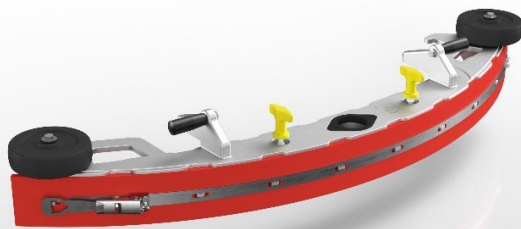

Tool-free

Tool-free replacement, swapping, or inspection of main components for brushes, squeegee, and blades.
Self adjusting side skirt



Integrated storage bin

Integrated storage bin for pickup of small debris and storage of spray bottles, keys, etc.



Quick access to time-saving diagnostics

Fully embedded machine-diagnostics capability simplifies troubleshooting and reduces costs associated with service and downtime

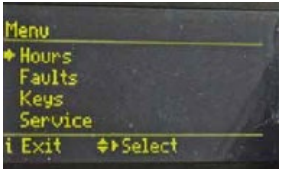

▶▶ E2 Main Controller		
J1-22 HORN		0
J2-8 FLOAT SW		0
J2-9 SIDE SWEEP		1
J2-10 LEVEL 1		1
◀Back	↕ Scroll	
▶▶ E2 Main Controller		
J1-10 EMERGENCY SW		1
J1-11 OBC INTERLOCK		0
J1-12 SEAT SW		1
J1-13 DUST GUARD SOL		0
◀Back	↕ Scroll	

Integrated impact-detection system reduces machine and facility damage by ensuring greater operator accountability

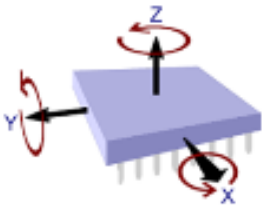

High productivity in compact dimensions

Key features

One-Touch™ button enables easy setup and brush-pressure adjustments.

3 (cyl) or 4 (disc) different setting levels:

- **Disc:** 100, 75, 52 kg
- **Cyl.:** 76, 59, 42 kg

Optional settings with the Superuser key, optimise brush pressure for varying types of smooth floors. This preserves floors, reduces brush wear, and optimises battery runtime for up to 4+ hours of operation.

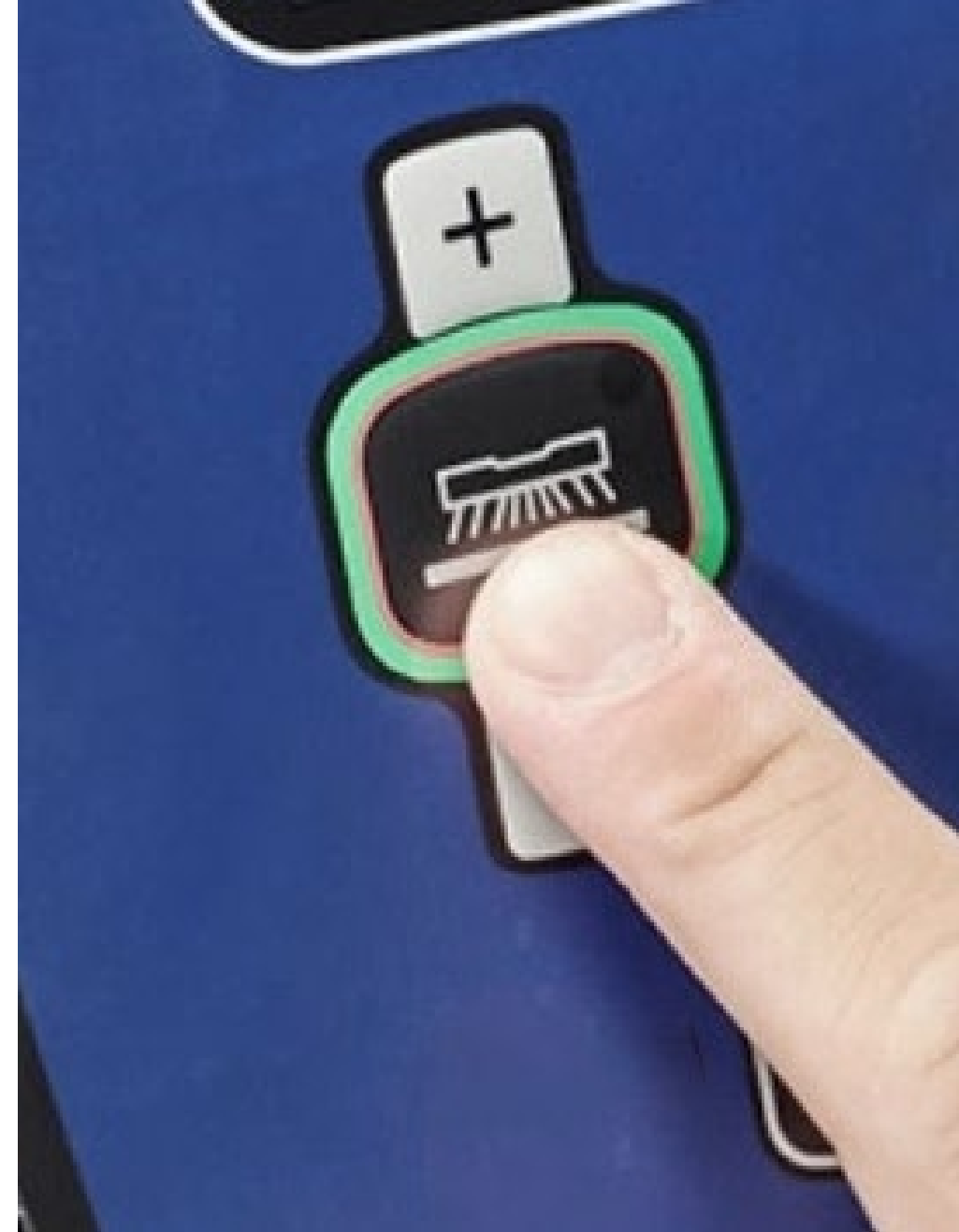

Impressive results and easy handling

Key features

Speed limiter

Speed limiter function reduces operator fatigue and accident risks during cleaning by allowing more precise speed-control while navigating around obstacles.

OLED display

OLED display is visible in brightly-lit conditions and at larger viewing angles.



Impressive results and easy handling

Key features

Intermittent Solution-OFF integrated into the steering wheel; can be activated **several metres before** turning **to halt water flow**

- Provides superior drying performance in turns
- Avoids splashing along curves in order to reduce or eliminate water residue on turns
- Minimises water consumption
- Automatically reactivates without user input after 5 seconds

Click-ON disc-scrub brush system for simple one-touch installation of brushes or pad holders





NILFISK